



Norsk olje & gass

FLANGE WORK



Handbook

September 2019/Rev.
06 Copyright © 2012
Norwegian Oil and Gas

Table of Contents

1. General Introduction 06-13

2. ASME RTJ 16-39

3. ASME RF/FF 42-65

4. API 6A Type 6B/BX 68-91

5. NCF5 Compact 93-123

6. Clamp Connections 126-147

7. Appendix 149-208

1.1 Background

Norwegian Oil and Gas has developed a handbook for working on flanged connections on hydrocarbon systems. The handbook can be downloaded from www.norskoljeoggass.no.

The handbook covers typical flanges and gaskets that are used in the petroleum industry and includes disassembly, inspection, alignment, installation and verification of flanges. The handbook is the basis for a training curriculum for flanges on hydrocarbon systems. The training curriculum can also be downloaded from www.norskoljeoggass.no.

1.2 HSE Precautions

1. Always maintain a good overview of the work site and who is involved in the work.
2. Do not use solutions that can harm people or tools.
3. Use proper personal safety equipment such as safety shoes, protective gloves, goggles, etc.
4. Hoses and connectors that are damaged may not be used.
5. To prevent the danger of pinching when using hydraulic torque tools, maintain a safe distance from reaction surfaces and the tool's counterhold during operation.
6. If there is no tool attached by itself to the nut/ bolt, it should be secured so that it doesn't fall off during the operation.
7. Check that there is an approved and signed work permit for the job before starting.
8. Cordon off the area before the job starts with approved cordoning bands.
9. When working at heights, the working area must be secured against falling objects (tools, bolts, gaskets, etc.).

1.3 Checklist for the Work Package

Normally, the following should be included in a work package:

1. Marked P&ID or ISO for each connection (pipe flange or valve connection) that shall be disassembled/assembled.
2. Bolting table.
3. Work description.
4. Material list.
5. Activity and inspection schedule.
6. Valve and lockout lists should be prepared and isolation/closure for engagement with the process equipment.

1.3 Checklist for the Work Package

The responsible planner for the job shall ensure that:

1. The correct gaskets or sealing rings are available, refer to pipe and valve specification or bolting table*.
2. Necessary tools are available for splitting and assembly of the relevant connections.
3. Necessary lifting equipment and jigs are available. Check the need for scaffolds and cordons for working at heights.
4. Necessary calibrated tools for bolt tightening and approved lubricants for bolts are available.
5. History of any problems with previous attachment of the connection are checked, and that relevant steps are planned.

**For transitions between different materials or pressure ratings, select a gasket for the most delicate material and the highest pressure. Use the lowest moment (it will be the moment for the weakest material) from the two relevant bolting tables when tightening.*

1.4 Execution

The person responsible for the execution (mechanic) and the equipment owner/system supervisor operator/process technician/area supervisor operator shall ensure that all valves that shall be operated on are labeled with label sheets.

Before opening/splitting equipment that is normally pressurized, the operational system supervisor (operator) and the executing mechanic shall personally ensure:

1. That there is an approved work permit.
2. That SJA (Safe Job Analysis and any pre-job conversation) is done if it is required.
3. That they are at the correct connection.
4. That isolation/lockout is correctly done and the system is depressurized and free of hydrocarbons.
5. That valves that shall be disassembled are in the half-open position, or as shown in the valve's maintenance handbook, so that the valve is free of pockets with enclosed pressure.
6. That the pipe hangers or pipe support are unloaded; this applies both to spring-loaded and fixed pipe hangers/pipe supports. Where there is a danger of tension in the pipe, initiate safety measures.

1.4 Execution

7. That the relevant insulation is removed and heat cables are disconnected.
8. The executing mechanic should review the manufacturer's user manual for the tool to be used on the job.
9. The executing mechanic should review the manufacturer's user manual for the tool to be used on the job.
10. Check that the pipe/equipment is secured against unanticipated shifting since this can occur during splitting of a flange.

2.1 Flange and Gasket	16-17
2.2 Disassembly	18-23
2.3 Inspection	24-25
2.4 Alignment	26-28
2.5 Assembly	29-35
2.6 Follow-up Inspection	36-39

2.1 Flange and Gasket

ASME Ring Type Joint, has a ring track fitted to oval or octagonal seals. Always use the type of ring that is specified in the bolting table. All R- and RX-rings that are used should be labeled with the manufacturer (name/logo), ring type, size and material specification.

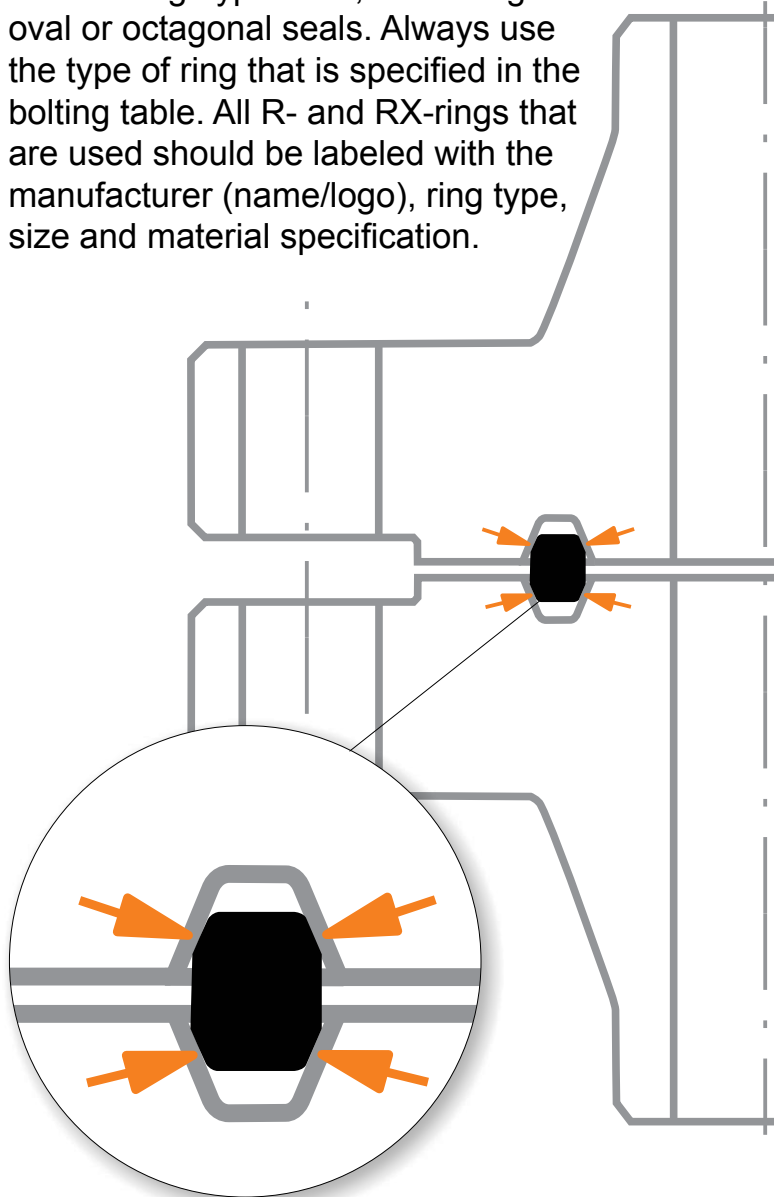

2.1 Flange and Gasket

During tightening, the ring molds to the contact surfaces in the ring track and establishes a metal-to-metal seal on both the inside and outside diameters. Since the deformation is permanent, the sealing ring cannot be reused. The main principle is that the ring material is softer than the material in the flanges. It is the gasket that should be deformed, and not the ring track.



2.2 Disassembly

2.2.1 Phase 1 (loosen bolts)



Check that the safety declaration matches the work description. Am I working on the correct flange?



During disassembly, never assume that the line is depressurized. All flanges should be disassembled as if there is pressure in the system. Pressure build-up can arise for several reasons.



Check the flange gap inside the ring with the help of a feeler gauge. If the distance is significantly less than what is specified in ASME B 16.5, the ring track is probably damaged. Report deviations to a technical supervisor and plan a remedy.

**See Appendix - "Table 7.4, ASME RTJ, gap"*



Check for tension in the pipe system.

2.2 Disassembly

2.2.1 Phase 1 (loosen bolts)

Check that the spring-loaded pipe supports are unloaded and placed in a locked position. That pipes and equipment are secured against shifting if support is missing with the removal of bolts in the flanges.



The bolts should be loosened according to the procedures in the section about avoiding uncontrolled tension in bolts and flanges.



CHECK THAT RELEVANT HSE PROCEDURES ARE FOLLOWED.



All deviations shall be logged in the “Activity and inspection schedule”, under “Notes” or on the back side.

2.2 Disassembly

2.2.1 Phase 1 (loosen bolts)



1. Use the maximum pump pressure for hydraulic wrenches.
2. It is recommended that you use four tools during disassembly.*



**For disassembly with hydraulic wrench tool:
see Appendix – Tool use, hydraulic wrench*

2.2 Disassembly

2.2.1 Phase 1 (loosen bolts)

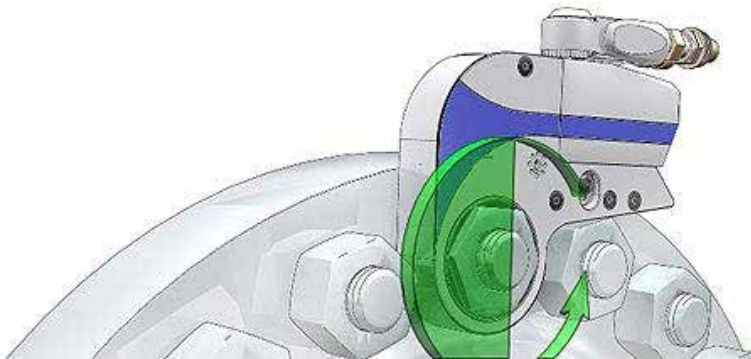

3. Ensure that the tool has an appropriate counterhold. The counterhold keys shall be placed on the same bolts as the wrenches. The counterhold keys shall prevent the nuts from rotating during disassembly.
4. Loosen 1/2 a turn at a time, and otherwise follow the procedure for cross wrenching, until the tension is taken off the bolts.
5. Loosen the bolts until there are a couple of millimeters clearance between the nuts and the flange. Carefully hit the flange with a hammer so that the gasket loosens.

2.2 Disassembly

2.2.2 Phase 2 (open flange)

**WARNING:**

With use of a hydraulic spreader, it is important to remember the following:

- If there is one or more bolts stuck in the flange's bolt hole, this can mean that there is tension in the pipe system. In that case, great care should be taken in further disassembly of the flange, and potentially securing the pipe should be considered.
- Contact a technical supervisor if there is doubt or a need for action.

**WARNING:**

With use of a hydraulic spreader, it is important to remember the following:

- Never stick fingers between the flanges before a safety block is installed and the spreaders are unloaded.
- Use the handle on the spreader when taking out or moving the tool.

2.2 Disassembly

2.2.2 Phase 2 (open flange)

1. For safety reasons, not all bolts should be taken out before the flange is open.
2. Use two spreaders, hydraulic or mechanical, opposite each other. This yields an even opening of the flange.
3. It is important that the spreaders have full contact with both flange surfaces before they are pressurized.
4. Insert safety blocks when the desired opening is reached using hydraulic spreaders. The flange will then rest on the safety blocks.
5. Keep the lowest bolts to prevent the sealing ring from falling out.
6. Then take out the sealing ring with its own tool. Be careful so that the gasket track and flange are not damaged.

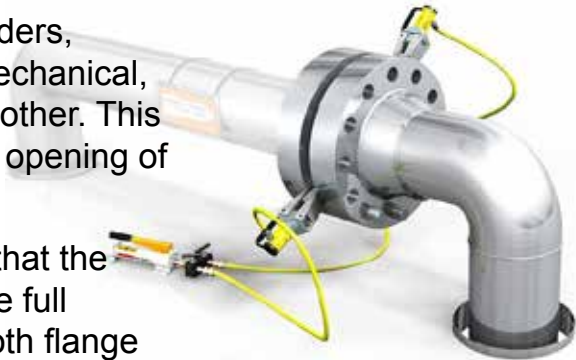

2.3 Inspection

Just before the flanges are disassembled and cleaned, the seal surfaces should be inspected. Inspection personnel may need to be called in to perform a visual inspection of pipe/equipment and measure the ring track.



2.3 Inspection

If there is damage, this should be reported to a technical supervisor. Any tension in the pipe system shall also be reported to a technical supervisor. Bolts and nuts should be checked for damage and the threads should be cleaned. Normally, galvanized bolts should not be reused.

1. The surface roughness of the inclined surfaces in the ring track should be checked visually against the RA standard (should have a reference point for roughness measurement).
2. The surface roughness should not exceed 1.6 micrometers (μm).



If the flanges are not assembled immediately, the gasket surface should be protected.

For more information about inspection and repair of flanges, refer to API 574 and ASME PCC-2-2011 article 3.5.



2.4 Alignment

2.4.1 Skewed connection



Tension in the pipe system that requires greater force to bring the flanges parallel to each other than is described in the procedure below, should be approved by a technical supervisor for evaluation of risk and relevant corrective measures.

See ASME PCC-1-2010 Appendix E for guidelines about alignment of flanges.

Permitted manufacturing tolerances can mean that the flange surfaces do not have the same distance around the entire flange connection, i.e. that the flange surfaces are not parallel when assembled. In such cases, the bolts must be tightened in the area where the distance between the flange surfaces is greatest.

2.4 Alignment

2.4.1 Skewed connection

1. The object with dealing with skews is to find out where the flanges have the largest gap.
2. Insert all the bolts in the flange connection.
3. With alignment of the flange connection, no more than half of the number of bolts in the flange connection should be used, and neighboring bolts shall not be used so that there is always at least one unused bolt between bolts that are used for alignment.
4. Tighten every second bolt in the area where the gap between the flange surfaces is greatest, with 30% of the given moment for a torque tool, or the B-pressure for a wrench tool. Use the lowest possible number of bolts to align the flanges.
5. The object when dealing with skews is to go around the entire flange connection several times during the process until the flanges are parallel.

2.4 Alignment

2.4.2 Parallel shifts



Flanges that are parallel-shifted should always be aligned before tightening can begin.

1. Use available alignment tool.
2. How the alignment tool is placed depends on your evaluation, and the space around the flange.
3. After the first alignment, all the bolts are inserted that can move freely in the flange's bolt holes. If not all the bolts move freely, the alignment tool should be moved, and the flange is aligned until all the bolts move freely.
4. Lock the flange connection when the flanges are parallel. This is done by screwing in all the bolts.

WARNING:

- Never try to align the flange connection with the help of the bolts alone.
- Always use an available alignment tool.
- If you are not able to pull the flange surfaces parallel, you should contact the nearest supervisor.

2.5 Assembly

Before tightening flanges, be sure to thoroughly plan and prepare for the job in advance.

1. Flange and seal surfaces should be checked for damage, corrosion and wear, and that the ring track is free of coatings from paint and preservative. There should not be any paint on the flange surfaces on any side of the ring track.
2. The flange's contact surface against the nuts should also be free of any thick layer of paint and preservative, which can cause bolts to fail to tighten after assembly. Only primer can be accepted under the contact surfaces of the nut.
3. Clean seal surfaces. Steel brushes or approved emery paper may be used for this. Approved solvents and cloths may be used for final cleaning.
4. Clean along the ring track. Ensure that the cleaning doesn't create radial tracks in the seal surface. It is especially important to remove imperfections in a radial direction.

2.5 Assembly

2.5.1 Sealing ring

For ASME RTJ, octagonal or oval metal rings may be used. The type of ring to be used is specified in the bolting chart/pipe specification.

1. Opening between the flanges should be larger than the thickness of the sealing ring so that this is not damaged during assembly.
2. A new sealing ring should always be inserted when sealing flanges that have been opened.
3. Check that you have the correct sealing ring according to the table and that it is free of damage. The ring's size and material quality is marked on the ring.
4. Rings with incomplete markings should not be used.
5. Insert the lowest bolts in the flange connection so that the sealing ring doesn't fall out.
6. Check that the ring sits correctly. It should be able to "rock" in the ring track.

Metal rings (RTJ) should be lubricated with a thin layer of acid-free Vaseline or a thin machine oil before you insert them so that point loads are avoided and so that it is easier to disassemble/remove the gasket again. Gaskets that are coated with PTFE should not be lubricated.

Grease or similar substances should not be used in the ring track, since this can prevent the ring from reaching full tightness.

2.5 Assembly

2.5.2 Bolts

The bolt's labeling is stamped on the one end of the bolt.

The bolting chart provides information about the bolts, the type of bolt and nut material, and any washers that should be used.

It includes a list of tools (for bolt diameters over 1"), number of bolts, bolt diameter, bolt length, key width, tightening force, the torque moment that the bolt should be tightened with, or A and B pressure if a hydraulic wrench equipment will be used.

The bolting chart also indicates which type of lubrication should be used on bolts and nuts.

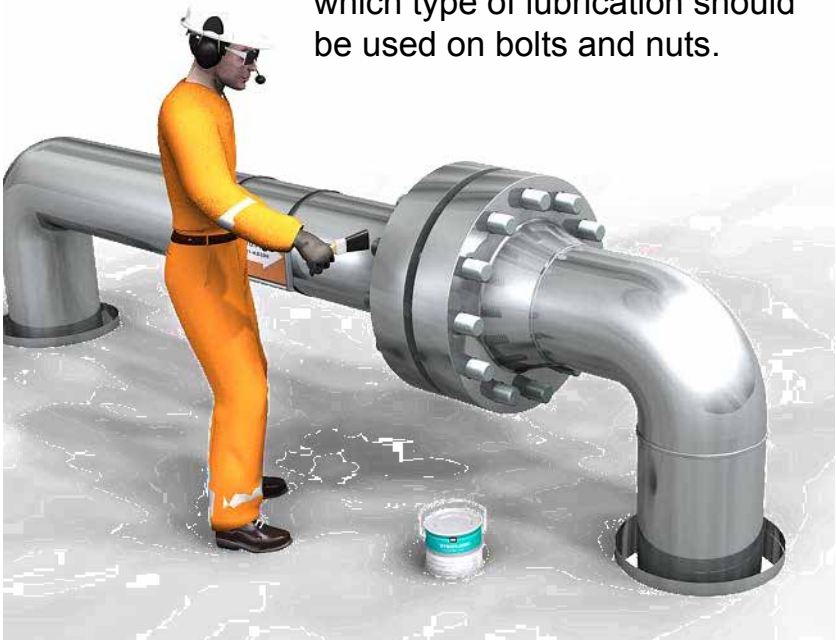

2.5 Assembly

2.5.2 Bolts

1. Nuts and bolts without markings should not be used.



2. The bolt's threads and the nut's contact surface should be checked for damage and wear.
3. Always use the lubricant that is specified in the bolting chart.
4. The bolt should not be lubricated before it is assembled in the flange connection.
5. The bolt's threads that engage with a nut should be lubricated on the side of the connection where the tool is installed. The bolt should also be lubricated on the other side.
6. Nuts are assembled correctly so that labeling is visible after assembly.

2.5 Assembly

2.5.2 Bolts

7. Nuts that are assembled with a wrench shall be lubricated on the contact surface towards the flange and on the first two threads near the flange. The bolt should also be lubricated on the other side.

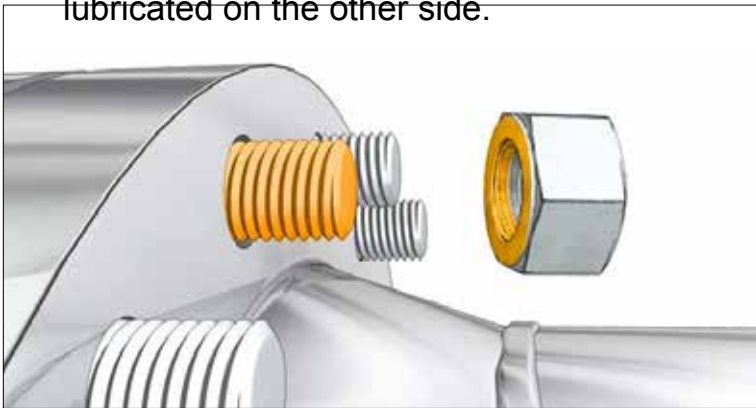

8. The bolts should move freely through the opposite flange.

The friction in a screw connection is difficult to predict accurately since this is dependent on a long list of variable factors. Since most of the moment is directed at countering friction, it is important that the threads of the bolt and nut are checked and lubricated.

2.5 Assembly

2.5.3 Tightening

Only approved tools should be used as listed in the bolting chart. If other tools are to be used, a new and approved bolting chart should be established.

If it is necessary to create special tools to tighten in tight spaces, this should be approved in accordance with the procedures of the operating company.

The following should be checked before the tool is used:

1. That the tool has valid calibration.
2. That the tool and equipment are in an acceptable condition before they are pressurized.
3. That tools and equipment are used in accordance with the supplier's recommendations.



2.5 Assembly

2.5.3 Tightening

The following safety steps should be taken when the tool is in use:

1. Maintain a safe distance from the tool while the tool is pressurized.
2. Do not attempt to hold or adjust the tool when it is in operation.
3. Do not leave the work-site with a pressurized tool.
4. Use a wire to secure loose tools with work at heights.

See Appendix "Safety moments".



Ref. different tightening procedures in "Appendix".

2.6 Follow-up Inspection

1. Check that there is at least 1 thread outside of the nut on each side of the bolt after tightening.
2. Check that there is an equal distance between the flange surfaces around the entire flange. Use a feeler gauge when you check this.
3. Any deviation should be reported to a technical supervisor.
4. Sign “Activity and inspection schedule”.
5. Fill out and sign “wrench sheet” and hang this on the flange.



2.6 Follow-up Inspection

The supervisor for the assembly should fill out and sign “Activity and inspection schedule” after each time that the flanges are assembled and the bolt connections are tightened with the prescribed moment/tightening force.

6. Old markings on the flange should be removed, and a new label sheet should be hung on the flange connection.



If it is necessary to use force beyond what is specified in “Alignment” to align the flange before normal tightening procedures can be started, this should be stated in the marking field in “Activity and inspection schedule” by the technician doing the work. This applies to all types of flange and clamp connections. The deviation should be recorded in the company’s system for handling deviations.

7. If different persons have been responsible for assembly and final bolt tightening, both should have signed with date at the end of a job.

2.6 Follow-up Inspection

Exceptions:

For non-dangerous help/support issues, the “Activity and inspection schedule”, and labeling of the flange connections may be ignored for ASME pressure ratings of 150 and 300, where the operating temperature is between 0° and 50°C.

1. If the equipment is put in operation immediately (with the technician executing and an operational supervisor present), the labelling of the flange connection and use of “Activity and inspection schedule” can be ignored.
2. Any type of deviations should be recorded in the company’s system for deviation management.



3.1 Flange and Gasket	42-44
3.2 Disassembly	44-49
3.3 Inspection	50-51
3.4 Alignment	52-53
3.5 Assembly	54-61
3.6 Follow-up Inspection	62-65

3.1 Flange and Gasket

ASME Raised Face is tightened by installing a flat gasket between the raised surfaces on the meeting flanges. The gasket types can be for example, graphite laminate, fiberglass (CGF), spiral gasket, kammprofile, rubber, plastic . Use the gasket that is specified in the bolting chart.

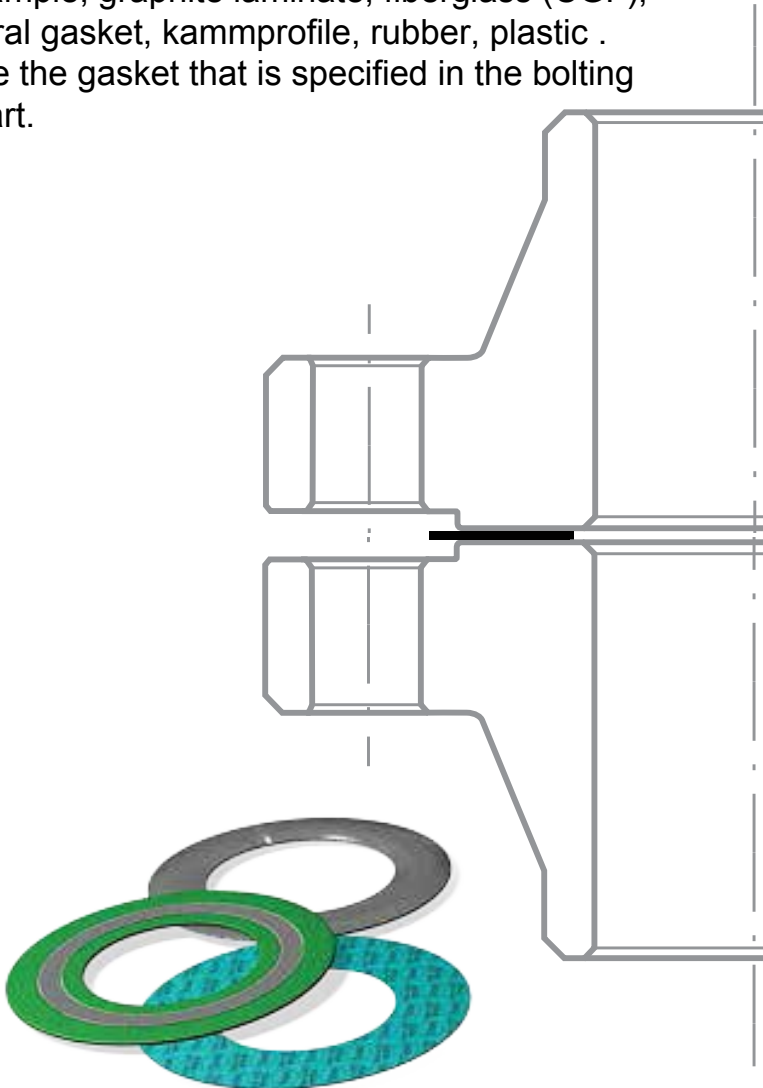

3.1 Flange and Gasket

During tightening, the gasket is compromised and is pressed down in a small track in the flange's contact face. These tracks are circular and are a part of the flange's design to provide the best possible seal. The tracks cover the entire contact face. The gaskets become permanently deformed and therefore should not be reused.



3.1 Flange and Gasket

Flanges of type ASME RF and ASME FF can have the following designs:

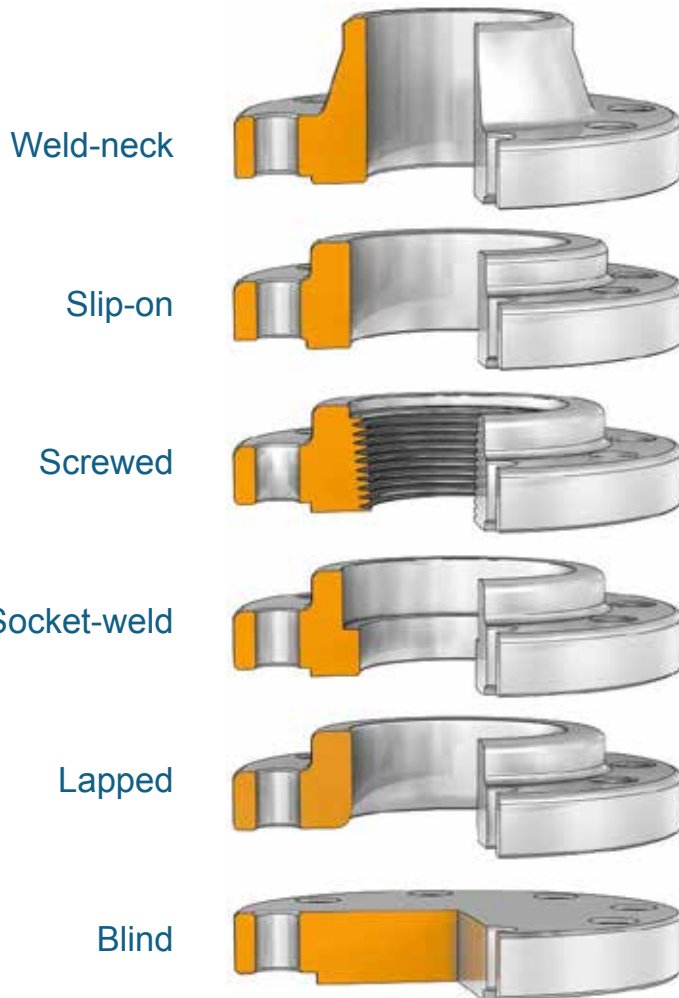

3.2 Disassembly

3.2.1 Phase 1 (loosen bolts)

Check that the safety declaration matches the work description. Am I working on the correct flange?



Check that the spring pipe supports are unloaded and set in a locked position.



During disassembly, never assume that the line is depressurized. All flanges should be disassembled as if there is pressure in the system. Pressure build-up can arise for several reasons.



The bolts should be loosened according to the procedures in the section about avoiding uncontrolled tension in bolts and flanges.

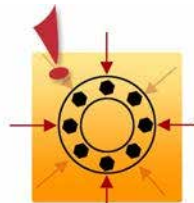

CHECK THAT RELEVANT HSE PROCEDURES ARE FOLLOWED.



All deviations shall be logged in the “Activity and inspection schedule”, under “Notes” or on the back side.

3.2 Disassembly

3.2.1 Phase 1 (loosen bolts)

1. Use the maximum pump pressure for hydraulic wrenches.
2. It is recommended that you use four tools during disassembly.*
3. Ensure that the tool has an appropriate counterhold. The counterhold keys shall be placed on the same bolts as the wrenches. The counterhold keys shall prevent the nuts from rotating during disassembly.
4. Loosen 1/2 a turn at a time, and otherwise follow the procedure for cross wrenching, until the tension is taken off the bolts.
5. Loosen the bolts until there are a couple of millimeters clearance between the nuts and the flange. Carefully hit the flange with a hammer so that the gasket loosens.

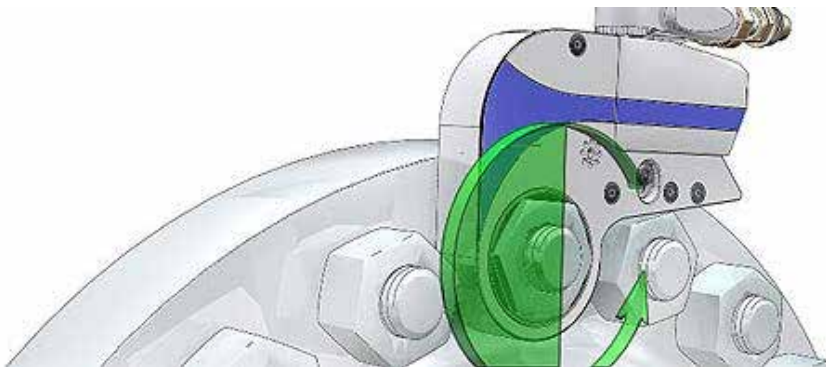

**For disassembly with hydraulic wrench tool:
see Appendix – Tool use, Hydraulic wrench.*

3.2 Disassembly

3.2.2 Phase 2 (open flange)

**WARNING:**

With use of a hydraulic spreader, it is important to remember the following:

If there is one or more bolts stuck in the flange's bolt hole, this can mean that there is tension in the pipe system. In that case, great care should be taken in further disassembly of the flange, and potentially securing the pipe should be considered. Contact a technical supervisor if there is doubt or a need for action.

1. For safety reasons, not all bolts should be taken out before the flange is open.
2. Use two spreaders, hydraulic or mechanical, opposite each other. This yields an even opening of the flange.
3. It is important that the spreaders have full contact with both flange surfaces before they are pressurized.
4. Insert safety blocks when the desired opening is reached using hydraulic spreaders. The flange will then rest on the safety blocks.
5. Keep the lowest bolts so that the gasket does not fall out.
6. Then remove the gasket with its own tool. Take care that the contact surface isn't damaged.

3.2 Disassembly

3.2.2 Phase 2 (open flange)

WARNING with use of a hydraulic spreader:

- Never stick fingers between the flanges before a safety block is installed and the spreaders are unloaded.
- Use the handle on the spreader when taking out or moving the tool.

**For disassembly with hydraulic wrench tool: see Appendix – Tool use, Hydraulic wrench.*



3.3 Inspection

Immediately after the flanges are disassembled, the seal surfaces should be cleaned and checked for damage. Additional inspection personnel may be needed to perform an internal, visual inspection of pipes/equipment. If there is damage, this should be reported to a technical supervisor. Any tension in the pipe system should be reported to a technical supervisor. Bolts and nuts should be checked for damage and the threads should be cleaned. Normally, galvanized bolts should not be reused.



- The surface roughness on the seal surface should be checked visually against the RA standard (should have a reference number for roughness measurement). The surface roughness should not exceed 6.3 micrometers (μm) for pressurized systems (3.2 micrometers (μm) for vacuum service).

For more information about inspection and repair of flanges, refer to API 574 and ASME PCC-2-2011 article 3.5.



3.3 Inspection



* For more information about troubleshooting leaking flanges see Appendix “Checklist for leaking flanges”.



If the flanges are not assembled immediately, the gasket surface should be protected.

3.4 Alignment

3.4.1 Skewed connection

If there is tension in the pipe system that requires greater force to bring the flanges parallel to each other than is described in the procedure below, this shall be approved by a technical supervisor for evaluation of risk and any corrective measures.



See ASME PCC-1-2010 Appendix E for extra guidelines.

Permitted manufacturing tolerances can mean that the flange surfaces do not have the same distance around the entire flange connection, i.e. that the flange surfaces are not parallel.



3.4 Alignment

3.4.1 Skewed connection

In such cases, the bolts must be tightened in the area where the distance between the flange surfaces is greatest.

1. The object with dealing with skews is to find out where the flanges have the largest gap.
2. Insert all the bolts in the flange connection.
3. With alignment of the flange connection, no more than half of the number of bolts in the flange connection should be used, and neighboring bolts shall not be used so that there is always at least one unused bolt between bolts that are used for alignment.
4. Tighten any bolt in the area where the gap between the flange surfaces is greatest, with 40% of the given moment for a torque tool, or 40% of the B-pressure for a wrench tool. Use the lowest possible number of bolts to align the flanges.
5. The object when dealing with skews is to go around the entire flange connection several times during the process until the flanges are parallel.

3.4 Alignment

3.4.2 Parallel shifts

Flanges that are parallel-shifted should always be aligned before tightening can begin.

1. Use available alignment tool.
2. How the alignment tool is placed depends on your evaluation, and the space around the flange.
3. After the first alignment, all the bolts are inserted that can move freely in the flange's bolt holes. If not all the bolts move freely, the alignment tool should be moved, and the flange is aligned until all the bolts move freely.
4. Lock the flange connection when the flanges are parallel. This is done by screwing in all the bolts.



WARNING:

- Never try to align the flange connection with the help of the bolts alone.
- Always use an available alignment tool.
- If you are not able to pull the flange surfaces parallel, you should contact the nearest supervisor.

3.5 Assembly

Before tightening flanges, be sure to thoroughly plan and prepare for the job in advance.

1. Check the flange and seal surface for damage, corrosion and wear, and that the gasket surface is free of coatings from painting and preservative.
2. The flange's contact surface against the nuts should also be free of any thick layer of paint and preservative, which can cause bolts to fail to tighten after assembly. Only primer painting can be accepted under the nut's contact surface against the flange.
3. Clean seal surfaces. Steel brushes or approved emery paper may be used for this. Approved solvents and cloths may be used for final cleaning.
4. Clean along the edge of the gasket surface. Ensure that the cleaning does not create radial tracks on the seal surface. It is especially important to remove imperfections in a radial direction. See ASME PCC-2-2011 Appendix D for acceptance limits of the flatness and damage on the gasket surface.

3.5 Assembly

3.5.1 Gasket

For ASME RF/FF flat gaskets or spiral gaskets should normally be used. The type of gasket to be used is specified in the bolting chart/pipe specification.

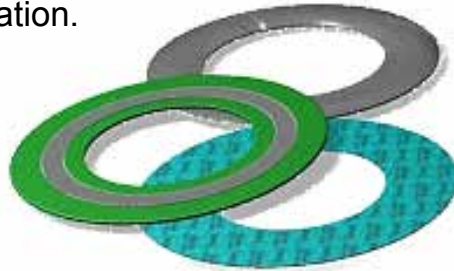

1. Opening between the flanges should be larger than the thickness of the gasket so that this is not damaged during assembly.
2. A new gasket should always be inserted when sealing flanges that have been opened.
3. Check that you have the correct gasket according to the bolting table and that it is free of damage.
4. NOTE! In some cases, especially with small pipe wall thickness, gaskets with ASME standard inner diameter can mean that the diameter is too small, so that the gasket sticks into the tube. This can be avoided by selecting a gasket with the correct inner diameter.

3.5 Assembly

3.5.1 Gasket

1. Insert the lowest bolts in the flange so that the gasket doesn't fall down. On larger flanges, the gasket is often soft and difficult to place and can easily fall down in the pipe. Therefore, be especially careful when you assemble gaskets in flanges that are assembled horizontally.
2. Check that the gasket is sitting correctly. Use a pocket light and verify that the gasket will sit up against the bolts all the way around the flanges. This is a good indication that the gasket has the right outer diameter. The bolts will center the gasket so that it is situated correctly on the contact surface.



3.5 Assembly

3.5.2 Bolts

The bolt's labeling is stamped on the one end of the bolt.

The bolting chart provides information about the bolts, the type of bolt and nut material that should be used. This includes a list of tools (for bolt diameters over 1"), number of bolts, bolt diameter, bolt length, key width, tightening force, the torque moment that the bolt should be tightened with, or A and B pressure if a hydraulic wrench equipment will be used. The bolting chart also indicates which type of lubrication should be used on bolts and nuts.



3.5 Assembly

3.5.2 Bolts

1. Nuts and bolts without markings should not be used.



2. The bolt's threads and the nut's contact surface should be checked for damage and wear.
3. Always use the lubricant that is specified in the bolting chart.
4. The bolt should not be lubricated before it is assembled in the flange connection.
5. The bolt's threads that engage with a nut should be lubricated on the side of the connection where the tool is installed. The bolt should also be lubricated on the other side.
6. Nuts are assembled correctly so that labeling is visible after assembly.

3.5 Assembly

3.5.2 Bolts

7. Nuts that are assembled with a wrench shall be lubricated on the contact surface towards the flange and on the first two threads near the flange. The bolt should also be lubricated on the other side.

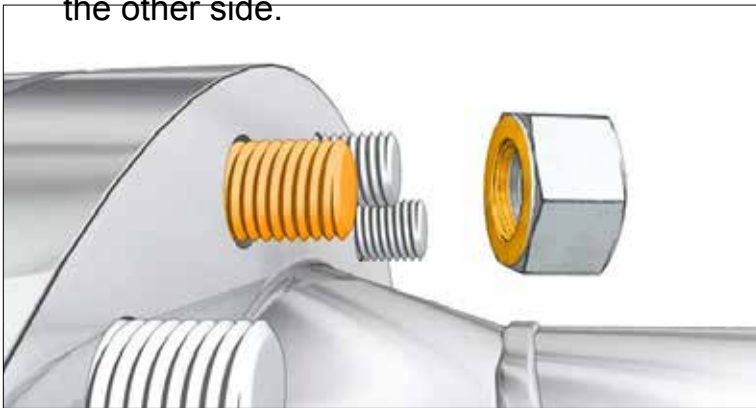

8. The bolts should move freely through the opposite flange.

The friction in a screw connection is difficult to predict accurately since this is dependent on a long list of variable factors. Since most of the moment is directed at countering friction, it is important that the threads of the bolt and nut are checked and lubricated.

3.5 Assembly

3.5.3 Tightening

Only approved tools should be used as listed in the bolting chart. If other tools are to be used, a new and approved bolting chart should be established.

If it is necessary to create special tools to tighten in tight spaces, this should be approved in accordance with the procedures of the operating company.

The following should be checked before the tool is used:

1. That the tool has valid calibration.
2. That the tool and equipment are in an acceptable condition before they are pressurized.
3. That tools and equipment are used in accordance with the supplier's recommendations.



3.5 Assembly

3.5.3 Tightening

The following safety steps should be taken when the tool is in use:

1. Maintain a safe distance from the tool while the tool is pressurized.
2. Do not attempt to hold or adjust the tool when it is in operation.
3. Do not leave the work-site with a pressurized tool.
4. Use a wire to secure loose tools with work at heights.

See Appendix "Safety moments".



Ref. different tightening procedures in "Appendix".

3.6 Follow-up Inspection

1. Check that there is at least 1 thread outside of the nut on each side of the bolt after tightening.
2. Check that there is an equal distance between the flange surfaces around the entire flange. Use a feeler gauge when you check this.
3. Any deviation should be reported to a technical supervisor.
4. Sign “Activity and inspection schedule”.
5. Fill out and sign “wrench sheet” and hang this on the flange.



3.6 Follow-up Inspection

The supervisor for the assembly should fill out and sign “Activity and inspection schedule” after each time that the flanges are assembled and the bolt connections are tightened with the prescribed moment/tightening force.

6. Old markings on the flange should be removed, and a new label sheet should be hung on the flange connection.



If it is necessary to use force beyond what is specified in “Alignment” to align the flange before normal tightening procedures can be started, this should be stated in the marking field in “Activity and inspection schedule” by the technician doing the work. This applies to all types of flange and clamp connections. The deviation should be recorded in the company’s system for handling deviations.

7. If different persons have been responsible for assembly and final bolt tightening, both should have signed with date at the end of a job.

3.6 Follow-up Inspection

Exceptions:

For non-dangerous help/support issues, the “Activity and inspection schedule”, and labeling of the flange connections may be ignored for ASME pressure ratings of 150 and 300, where the operating temperature is between 0° and 50°C.

1. If the equipment is put in operation immediately (with the technician executing and an operational supervisor present), the labelling of the flange connection and use of “Activity and inspection schedule” can be ignored.
2. Any type of deviations should be recorded in the company’s system for deviation management.



4.1 Flange and Gasket Type 6B	68-69
4.1 Flange and Gasket Type 6BX	70-71
4.2 Disassembly	72-76
4.3 Inspection	77-79
4.4 Alignment	80-82
4.5 Assembly	83-87
4.6 Tightening	88-89
4.7 Follow-up Inspection	90-91

4.1 Flange and Gasket Type 6B

API 6A type 6B is used from and including API pressure ratings 2,000 PSI to 5,000 PSI. The ring track is designed for type R (oval, octagonal) or RX sealing rings. Always use the type of ring that is specified in the bolting table.

All gasket rings shall have the following minimum labeling on the outside: manufacturer name or identification, ring type (R, RX or BX) and material identification. Rings that lack required identification shall not be used.

During tightening, the ring molds to the contact surfaces in the ring track and establishes a metal-to-metal seal. The RX ring primarily tightens on the outside of the ring track. Since the deformation is permanent, the sealing ring cannot be reused.

After tightening API 6A type 6B flanges are designed so that there is a gap between the flanges inside the ring or that the bolts have reached the given tension. Flanges of this type can be both Raised Face and Flat Face.

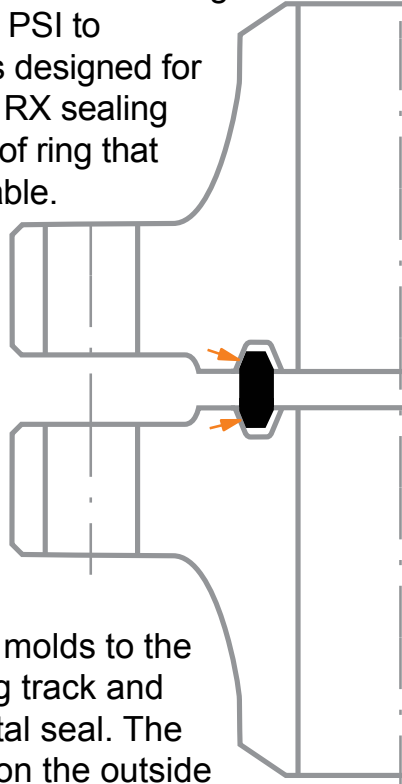

4.1 Flange and Gasket Type 6B

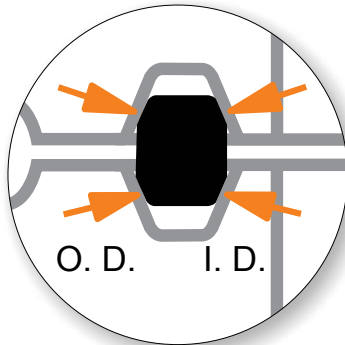

“R” ring track with R octagonal ring

The seal surface begins about 20% from the top. The seal surface makes up about 40% of the ring track on both sides.

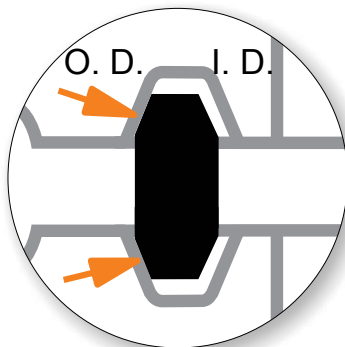

“R” ring track with an RX ring

The seal surface begins about 20% from the top. The seal surface makes up about 40% of the ring track on the outer diameter (O. D.).

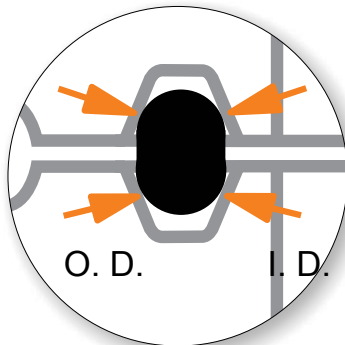

“R” ring track with R oval ring

The seal surface begins about 20% from the top. The seal surface makes up about 40% of the ring track on both sides.

4.1 Flange and Gasket Type 6BX

API 6A type 6BX is used from and including API pressure ratings 5,000 PSI to 20,000 PSI. The ring track is designed only for BX type sealing rings. The BX ring always has a hole for pressure equalization.

With tightening, the ring molds to the contact surfaces in the ring track and establishes a metal-to-metal seal that tightens on the inner and outer diameter. Since the deformation is permanent, the sealing ring cannot be reused.

After the tightening of API 6A type 6BX flanges, the flange surfaces inside by the ring shall go completely or nearly completely together (almost no measurable gap).

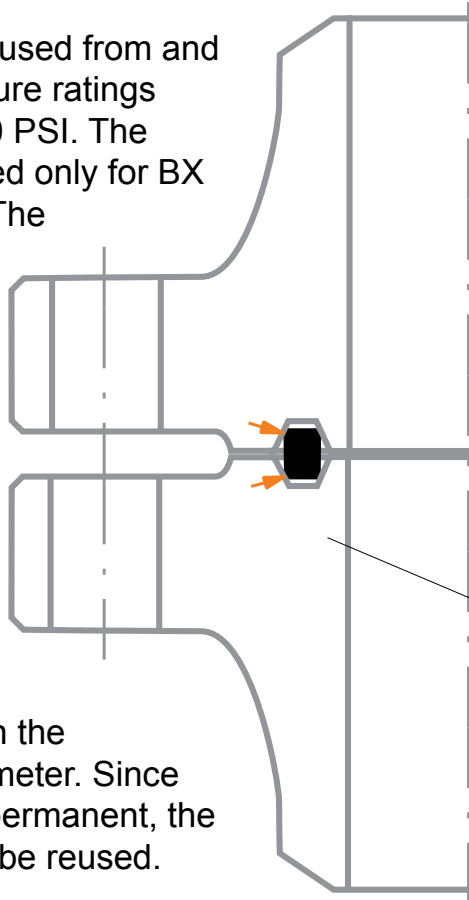

4.1 Flange and Gasket Type 6BX

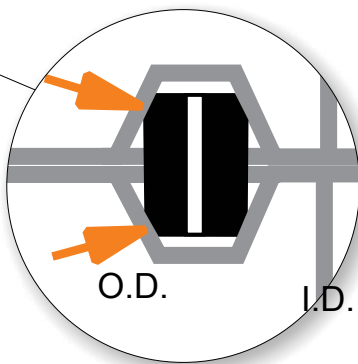

API 6A Type 6B/BX

**“BX” ring track with BX ring**

The seal surface begins about 20% from the top.

The seal surface makes up about 40% of the ring track, with reliable tightening only on the outer diameter (O.D.).

4.2 Disassembly

4.2.1 Phase 1 (loosen bolts)



Check that the safety declaration matches the work description. Am I working on the correct flange?



Check for tension in the pipe system.



During disassembly, never assume that the line is depressurized. All flanges should be disassembled as if there is pressure in the system. The pressure build-up can occur for several reasons.

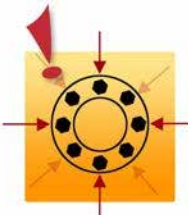

The bolts should be loosened according to the procedures in the section about avoiding uncontrolled tension in bolts and flanges.

4.2 Disassembly

4.2.1 Phase 1 (loosen bolts)

CHECK THAT RELEVANT HSE PROCEDURES ARE FOLLOWED.



All deviations shall be logged in the “Activity and inspection schedule”, under “Notes” or on the back side.

4.2 Disassembly

4.2.1 Phase 1 (loosen bolts)

1. Use the maximum pump pressure for hydraulic wrenches.
2. It is recommended that you use four tools during disassembly.*



**For disassembly with hydraulic wrench tool:
see Appendix – Tool use, Hydraulic wrench.*

4.2 Disassembly

4.2.1 Phase 1 (loosen bolts)

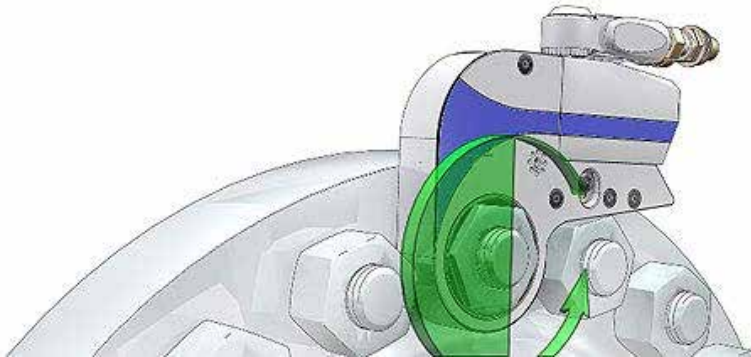

3. Ensure that the tool has an appropriate counterhold. The counterhold keys shall be placed on the same bolts as the wrenches. The counterhold keys shall prevent the nuts from rotating during disassembly.
4. Loosen 1/2 a turn at a time, and otherwise follow the procedure for cross wrenching, until the tension is taken off the bolts.
5. Loosen the bolts until there are a couple of millimeters clearance between the nuts and the flange. Carefully hit the flange with a hammer so that the gasket loosens.

4.2 Disassembly

4.2.2 Phase 2 (open flange)

**WARNING:**

With use of a hydraulic spreader, it is important to remember the following:

- If there is one or more bolts stuck in the flange's bolt hole, this can mean that there is tension in the pipe system. In that case, great care should be taken in further disassembly of the flange, and potentially securing the pipe should be considered.

**WARNING:**

With use of a hydraulic spreader, it is important to remember the following:

- Never stick fingers between the flanges before a safety block is installed and the spreaders are unloaded.
- Use the handle on the spreader when taking out or moving the tool.

4.3 Inspection

4.3.1 Phase 2 (open flange)

1. For safety reasons, not all bolts should be taken out before the flange is open.
2. Use two spreaders, hydraulic or mechanical, opposite each other. This yields an even opening of the flange.
3. It is important that the spreaders have full contact with both flange surfaces before they are pressurized.
4. Insert safety blocks when the desired opening is reached using hydraulic spreaders. The flanges will then rest on the safety blocks.
5. Keep the lowest bolts to prevent the sealing ring from falling out.
6. Then take out the sealing ring with its own tool. Be careful so that the gasket track and flange are not damaged.



4.3 Inspection



Immediately after the flanges are disassembled and cleaned, they should be inspected. Additional inspection personnel may be needed to perform an internal, visual inspection of pipes/equipment and inspect the ring track. If there is damage, this

should be reported to a technical supervisor.

Any tension in the pipe system shall also be reported to a technical supervisor.

Bolts and nuts should be checked for damage and the threads should be cleaned. Normally, galvanized bolts should not be reused.

1. The surface roughness of the inclined surfaces in the ring track should be checked visually against the RA standard (should have a reference point for roughness measurement).
2. Type 6B: The surface roughness should not exceed RA like or less than 1.6 micrometers (μm).
3. Type 6BX: The surface roughness should not exceed RA like or less than 0.8 micrometers (μm).

4.3 Inspection

4.3.2 Inspection – Troubleshooting

For more information about troubleshooting leaking flanges refer to: Appendix “Checklist for leaking flanges”.



If the flanges are not assembled immediately, the gasket surface should be protected.

For more information about inspection and repair of flanges, refer to API 574 and ASME PCC-2-2011 article 3.5.



4.4 Alignment

4.4.1 Skewed connection



If there is tension in the pipe system that requires greater force to bring the flanges parallel to each other than the force described in the procedure below, this shall be approved by a technical supervisor for evaluation of risk and any corrective measures.

Permitted manufacturing tolerances can mean that the flange surfaces do not have the same distance around the entire flange connection, i.e. that the flange surfaces are not parallel.

1. The object with dealing with skews is to find out where the flanges have the largest gap.
2. Insert all the bolts in the flange connection.
3. With alignment of flanged connections, no more than half the number of bolts in the flange connection should be used, neighboring bolts should not be used, so that there is always at least one unused bolt between bolts that are used for alignment. See ASME PCC-1-2010 Appendix E for guidelines about alignment.

4.4 Alignment

4.4.1 Skewed connection

4. Tighten any bolt in the area where the gap between the flange surfaces is greatest, with 40% of the given moment for a torque tool, or 40% of the B-pressure for a wrench tool. Use a lowest possible number of bolts to pull the flanges together.
5. The object when dealing with skews is to go around the entire flange connection several times during the process until the flanges are parallel.



4.4 Alignment

4.4.2 Parallel shifts



Flanges that are parallel-shifted should always be aligned before tightening can begin.

1. Use available alignment tool.
2. How the alignment tool is placed depends on your evaluation, and the space around the flange.
3. After the first alignment, all the bolts are inserted that can move freely in the flange's bolt holes. If not all the bolts move freely, the alignment tool should be moved, and the flange is aligned until all the bolts move freely.
4. Lock the flange connection when the flanges are parallel. This is done by screwing in all the bolts.

WARNING:

- Never try to align the flange connection with the help of the bolts alone.
- Always use an available alignment tool.
- If you are not able to pull the flange surfaces parallel, you should contact the nearest supervisor.

4.5 Assembly

Before tightening flanges, be sure to thoroughly plan and prepare for the job in advance.

1. Flange and seal surface are checked for damage, corrosion and wear, and that the seal surface is free of coatings from painting and preservatives in the seal track and on both sides of this.
2. The flange's contact surface against the nuts should also be free of any thick layer of paint and preservative, which can cause bolts to fail to tighten after assembly. Only primer is acceptable under nuts.
3. Clean seal surfaces. Steel brushes or approved emery paper may be used for this. Approved solvents and cloths may be used for final cleaning.
4. Clean along the ring track. Ensure that the cleaning does not cause radial tracks in the ring track. It is especially important to remove imperfections in a radial direction.

4.5 Assembly

4.5.1 Sealing ring

For API 6A type 6B flanges, R and RX metal rings may be used. For API 6A type 6BX flanges, BX metal rings may be used. The type of ring to be used is specified in the bolting chart/pipe specification.

1. Opening between the flanges should be larger than the thickness of the sealing ring so that this is not damaged during assembly.
2. A new sealing ring should always be inserted when sealing flanges that have been opened.
3. Check that you have the correct sealing ring according to the bolting table and that it is free of damage. All gasket rings shall have the following minimum labeling on the outside: manufacturer name or identification, ring type (R, RX or BX) and material identification.
4. Rings with incomplete markings should not be used.
5. Insert the lowest bolts in the flange connection so that the sealing ring doesn't fall out.

4.5 Assembly

4.5.1 Sealing ring

Check that the ring sits correctly. It should be able to “rock” in the ring track.



Metal rings (RTJ) shall be lubricated with a thin layer of acid-free Vaseline or thin machine oil before they are put in. This is so that point loads are avoided and so that it is easier to disassemble/remove the gasket again. Gaskets that are coated with PTFE should not be lubricated.

Grease or similar substances should not be used in the ring track, since this can prevent the ring from reaching full tightness.

4.5 Assembly

4.5.2 Bolts

The bolt's labeling is stamped on the one end. The bolting chart provides information about the bolts, the type of bolt and nut material that should be used.



It includes a list of tools (for bolt diameters over 1"), number of bolts, bolt diameter, bolt length, key width, tightening force, the torque moment that the bolt should be tightened with, or A and B pressure if a hydraulic wrench equipment will be used.

The bolting chart also indicates which type of lubrication should be used on bolts and nuts, and any washers.

1. Nuts and bolts without markings should not be used.
2. The bolt's threads and the nut's contact surface should be checked for damage and wear.
3. Always use the lubricant that is specified in the bolting chart.

4.5 Assembly

4.5.2 Bolts

4. The bolt should not be lubricated before it is assembled in the flange connection.
5. The bolt's threads that are engaged with the nut shall be lubricated on the side of the flange connection where the tool is installed. The bolt should also be lubricated on the other side.
6. Nuts are assembled correctly so that labeling is visible after assembly.
7. Nuts that are assembled with a wrench shall be lubricated on the contact surface towards the flange and on the first two threads near the flange. The bolt should also be lubricated on the other side.

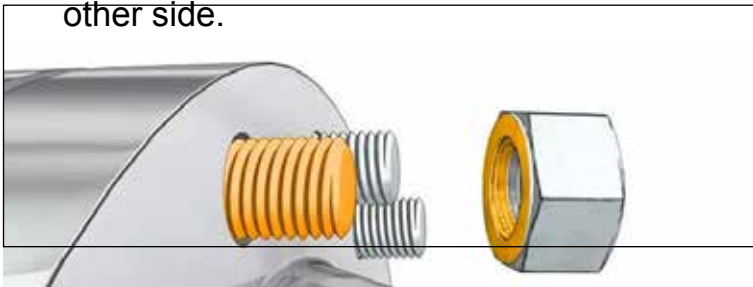

8. The bolts should move freely through the opposite flange.

The friction in a screw connection is difficult to predict accurately since this is dependent on a long list of variable factors. Since most of the moment is directed at countering friction, it is important that the threads of the bolt and nut are checked and lubricated.

4.6 Tightening

Only approved tools should be used as listed in the bolting chart. If other tools are to be used, a new and approved bolting chart should be established.

If it is necessary to create special tools to tighten in tight spaces, this should be approved in agreement with the procedures of the operating company.

The following should be checked before the tool is used:

1. That the tool has valid calibration.
2. That the tool and equipment are in an acceptable condition before they are pressurized.
3. That tools and equipment are used in accordance with the supplier's recommendations.



4.6 Tightening

The following safety steps should be taken when the tool is in use:

1. Maintain a safe distance from the tool while the tool is pressurized.
2. Do not attempt to hold or adjust the tool when it is in operation.
3. Do not leave the work-site with a pressurized tool.
4. Use a wire to secure loose tools with work at heights.

See Appendix "Safety moments".



Ref. different tightening procedures in "Appendix".



4.7 Follow-up Inspection

1. Check that there is at least 1 thread outside of the nut on each side of the bolt after tightening.
2. Check that there is an equal distance between the flange surfaces around the entire flange. Use a feeler gauge when you do this check.
3. Any deviation should be reported to a technical supervisor.
4. Sign “Activity and inspection schedule”.
5. Fill out and sign “wrench sheet” and hang this on the flange.



4.7 Follow-up Inspection

The supervisor for the assembly should fill out and sign “Activity and inspection schedule” after each time that the flanges are assembled and the bolt connections are tightened with the prescribed moment/tightening force.

6. Old markings on the flange should be removed, and a new label sheet should be hung on the flange connection.



If it is necessary to use force beyond what is specified in “Alignment” to align the flange before normal tightening procedures can be started, this should be stated in the marking field in “Activity and inspection schedule” by the technician doing the work. This applies to all types of flange and clamp connections. The deviation should be recorded in the company’s system for handling deviations.

7. If different persons have been responsible for assembly and final bolt tightening, both should have signed with date at the end of a job.

5.1 Flange and Gasket	94-95
5.2 Disassembly	96-103
5.3 Inspection	104-108
5.4 Alignment	109-113
5.5 Assembly	114-119
5.6 Tightening	120-121
5.7 Follow-up Inspection	122-123

5.1 Flange and Gasket

The characteristic of compact flanges is that they close completely after tightening. This means that the flange surfaces are not exposed to corrosion and erosion problems, and the flange has an environmental seal around the outer diameter. The compact flange is also both smaller and lighter than conventional ASME flanges. Because of the design of the flange, there are strict requirements that fabrication tolerances be met.

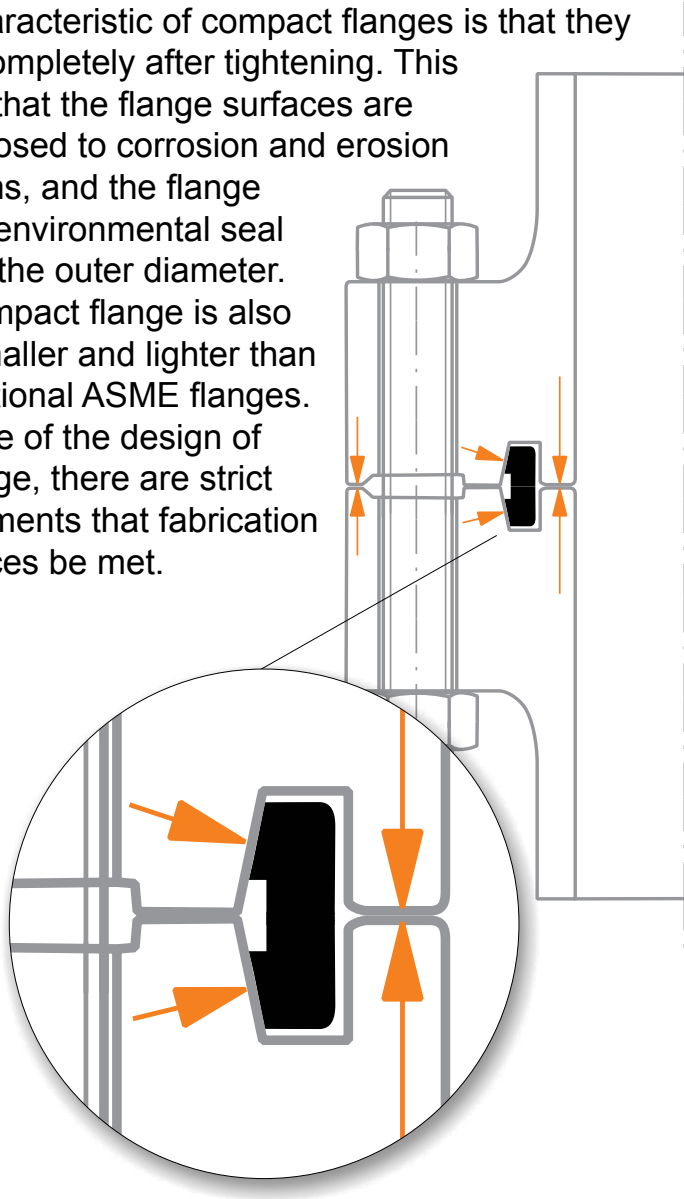

5.1 Flange and Gasket

The compact flange's sealing ring, the IX-ring or the HX-ring, has a characteristic indented track on the outer edge. All labeling is on the inside of the ring. The main seal is the ring, and this is tighter on the outer diameter. If the seal fails, you will get a pressure build-up on the inside of the ring. The higher the pressure, the tighter the ring.



Metal-to-metal sealing ring deformation is checked. The sealing force between ring and ring track is not affected by dynamic forces since the tension in the bolts is taken up by the flange surface. This contributes to a static connection with nearly no flange movement, even when large dynamic forces are transmitted. This eliminates the need for post tightening of the bolts.

5.2 Disassembly

5.2.1 Phase 1 (loosen bolts)



Check that the safety declaration matches the work description. Am I working on the correct flange?



Check that the spring-loaded pipe supports are unloaded and placed in a locked position.



During disassembly, never assume that the line is depressurized. All flanges should be disassembled as if there is pressure in the system. Pressure build-up can arise for several reasons.

5.2 Disassembly

5.2.1 Phase 1 (loosen bolts)

The bolts should be loosened according to the procedures in the section about avoiding uncontrolled tension in bolts and flanges.

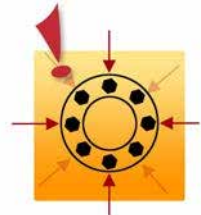

CHECK THAT RELEVANT HSE PROCEDURES ARE FOLLOWED.



All deviations shall be logged in the “Activity and inspection schedule”, under “Notes” or on the back side.

5.2 Disassembly

5.2.1 Phase 1 (loosen bolts)

1. Use the maximum pump pressure for hydraulic wrenches.
2. It is recommended that you use four tools during disassembly.*



**For disassembly with hydraulic wrench tool: see Appendix – Tool use, Hydraulic wrench.*

5.2 Disassembly

5.2.1 Phase 1 (loosen bolts)

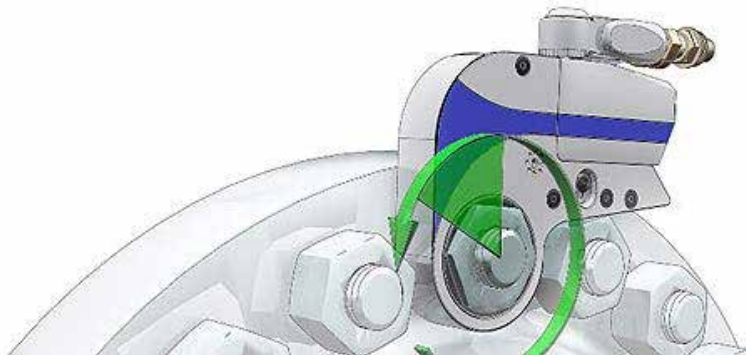

3. Ensure that the tool has an appropriate counterhold. The counterhold keys shall be placed on the same bolts as the wrenches. The counterhold keys shall prevent the nuts from rotating during disassembly.
4. Loosen 1/6th of a turn at a time (60 degrees), and otherwise follow the procedure for cross wrenching, until the tension is taken off the bolts.
5. Loosen the bolts until there are a couple of millimeters clearance between the nuts and the flange. Carefully hit the flange with a hammer so that the gasket loosens.

5.2 Disassembly

5.2.2 Phase 2 (open flange)

**WARNING:**

With use of a hydraulic spreader, it is important to remember the following:

- If there is one or more bolts stuck in the flange's bolt hole, this can mean that there is tension in the pipe system. In that case, great care should be taken in further disassembly of the flange, and potentially securing the pipe should be considered.

**WARNING:**

With use of a hydraulic spreader, it is important to remember the following:

- Never stick fingers between the flanges before a safety block is installed and the spreaders are unloaded.
- Use the handle on the spreader when taking out or moving the tool.

5.2 Disassembly

5.2.2 Phase 2 (open flange)

With disassembly of compact flanges, one should be very careful so that the flange's seal surfaces are not damaged.

For compact flanges, it is recommended that you use a flange spreader that can be installed in the flange's bolt hole.



5.2 Disassembly

5.2.2 Phase 2 (open flange)

Use of standard flange spreaders has been discontinued since these can damage the compact flange's seal along the outer diameter.

1. For safety reasons, not all bolts should be removed before the flange is open. Just take out the bolts that must be removed to get access to flange spreaders.
2. Use two spreaders, hydraulic or mechanical, opposite each other. This yields an even opening of the flange.



5.2 Disassembly

5.2.2 Phase 2 (open flange)

3. It is important that the spreaders installed in the flange's bolt hole do not come in contact with the opposite flange. Use the correct dimension for the rings in relation to the diameter of the flanges.

4. Insert safety blocks when the desired opening is reached using hydraulic spreaders.



5. Keep the lowest bolts to prevent the sealing ring from falling out.
6. Then take out the sealing ring with its own tool. Be careful that neither the ring track, seal surfaces or a flange is destroyed.

5 NCF5 Compact

5.3 Inspection



Immediately after the flanges are disassembled and cleaned, they should be inspected. Inspection personnel may need to be called in to perform a visual inspection of pipe/equipment and measure the ring track. If there is damage, this should be reported to a technical supervisor. Any tension in the pipe system should be reported to a technical supervisor.

Bolts and nuts should be checked for damage and the threads should be cleaned. Normally, galvanized bolts should not be reused.

5.3 Inspection

The surface roughness of the following seal surfaces should be checked visually against the RA standard (should have a reference number for roughness measurement).

1. Outer construction surface in the ring track: The surface roughness should not exceed RA like or less than 0.8 micrometers (μm).
2. The flange's heel: The surface roughness should not exceed RA like or less than 0.8 micrometers (μm).
3. The flange surfaces/ring track generally: The surface roughness should not exceed RA like or less than 1.6 micrometers (μm).

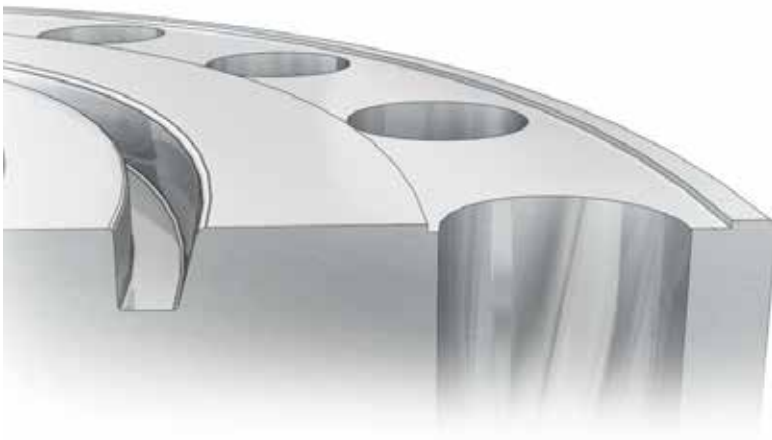

5.3 Inspection



Polish away all types of slight damage to the seal surfaces, the heel and the contact surfaces in the ring track with a fine polishing cloth in the direction of the flange circle. Significant flange damage usually requires remachining. Contact the flange supplier for machining tolerances and advice about acceptable machining.

5.3 Inspection

5.3.1 Acceptance criteria

Localizing damage	Steps
Tracks or scratches that cover more than 3/4th of the heel width.	Sand with fine emery paper to the desired depth. Use emery paper number: 240.
Tracks or scratches/ damage to the hole that covers 3/4th or more of the width of the heel width.	Sand with fine emery paper to the desired depth. Use emery paper number 240. If the depth after sanding exceeds 0.1 mm, repair with Loctite 510.
Scratches in the sealing ring contact surface.	Sand with fine emery paper. Use emery paper number 240.
Outer contact edge on flange.	Remove all unevenness, etc. with sanding or filing.
Damage to the sealing ring.	Change with a new one.

For more information about inspection and repair of flanges, refer to NORSOK L-005.



5.3 Inspection



For more information about inspection and repair of flanges, refer to NORSOK L-005.



If the flanges are not assembled immediately, the gasket surface should be protected.



For more information about troubleshooting with leakage of flanges refer to: Appendix – “Checklist for leaking flanges”.

5.4 Alignment

5.4.1 Skewed connection

When the flanges are pulled together, the gasket ensures that they are centered. The bolt holes should be centered so that the bolts move freely through the opposite flange.

Tension in the pipe system that requires greater force to bring the flanges parallel to each other than described in the procedure below for “Alignment”, should be approved by the technical supervisor for evaluation of risk and any corrective measures.



Permitted manufacturing tolerances can mean that the flange surfaces do not have the same distance around the entire flange. In other words, that the flange surfaces are not parallel. In such cases, the bolts must be tightened in the area where the distance between the flange surfaces is greatest.



5.4 Alignment

5.4.1 Skewed connection

The goal of handling skews is to find out where the flanges have the largest gap.

1. Insert all the bolts in the flange.
2. When aligning flanged connections, no more than half the number of bolts in the flange connection should be used.
3. Neighboring bolts should not be used, so that there is always at least one unused bolt between bolts that are used for alignment.
4. None of the used bolts should be loaded more than 30% of the given moment in the bolting chart. (Moment for compact flanges is given in NORSOK L-005, part 5.)
5. The object when dealing with skews is to go around the entire flange connection several times during the process until the flanges are parallel.

5.4 Alignment

5.4.1 Skewed connection



5.4 Alignment

5.4.2 Parallel shifts



Flanges that are parallel-shifted should always be aligned before tightening can begin.

1. Use available alignment tool.
2. How the alignment tool is placed depends on your assessment, and the space around the flange.
3. After the first alignment, all the bolts are inserted that can move freely in the flange's bolt holes. If not all the bolts move freely, the alignment tool should be moved, and the flange is aligned until all the bolts move freely.
4. Lock the flange connection when the flanges are parallel. This is done by screwing in all the bolts.

WARNING:

- Never try to correct the flange connection with the help of the bolts alone.
- Always use an available alignment tool.
- If you are not able to pull the flange surfaces parallel, you should contact the nearest supervisor.

5.4 Alignment

5.4.2 Parallel shifts

Before tightening flanges, be sure to thoroughly plan and prepare for the job in advance.

1. Flange, gasket surfaces and ring tracks are checked for damage, corrosion and wear, and that the seal surface is free of coatings from painting and preservative in the gasket surface.
2. The flange's contact surface against the nuts should also be free of any paint and preservative. Only primer is permitted.
3. Clean the ring track, seal surface and heel and along the outer diameter. Approved emery paper may be used for this. Approved solvents and cloths may be used for final cleaning. Clean along the ring track and along the heel and outer diameter, so that there are no radial tracks on the surfaces. You should pay careful attention to damage in a radial direction.

5 NCF5 Compact

5.5 Assembly

NCF5 Compact



5.5 Assembly

5.5.1 Sealing ring

For NCF5 Compact only IX rings can be used. The required material quality for the ring to be used is specified in the bolting chart/pipe specification. IX rings for compact flanges with the designation NCF5 have a color code and material information as in Norsok L-005:

BLUE:	Carbon steel
YELLOW:	22Cr. Duplex steel
BLACK:	6Mo Austenitic steel
ORANGE:	17/4 PH Martensitic steel



Check all of the markings on the ring to be certain that it has the correct material quality in the event of a deviation within the color coding.

5.5 Assembly

5.5.1 Sealing ring

1. Opening between the flanges should be larger than the thickness of the sealing ring so that this is not damaged during assembly.
2. A new sealing ring should always be inserted when sealing flanges that have been opened.
3. Check that you have the correct sealing ring according to the table and that it is free of damage. The ring's size and material quality is marked on the ring.
4. Insert the lowest bolts in the flange connection so that the sealing ring doesn't fall out.
5. Check that the ring sits correctly. It should be able to "rock" in the ring track.

5.5 Assembly

5.5.1 Sealing ring

PTFE covered IX rings should not be lubricated. Grease or similar substances should not be used in the ring track, since this can prevent the ring from reaching full tightness.

Compact flange connections should be closed as soon as possible after assembly. If this cannot occur immediately, the gap between the flanges should be protected. Suitable tape should be used.

During assembly of a new pipe system, a pipe and a connection piece should be assembled along the pipe line before you assemble the next connection.



5.5 Assembly

5.5.2 Bolts

The bolt's labeling is stamped on one end. The bolting chart provides information about the bolts, the type of bolt and nut material that should be used.



It includes the tools, number of bolts, bolt diameter, bolt length, key width, tightening force, the torque moment that the bolt should be tightened with, or A and B pressure if a hydraulic wrench equipment will be used.

The bolting chart also indicates which type of lubrication should be used on bolts and nuts.

1. Nuts and bolts without markings should not be used.
2. The bolt's threads and the nut's contact surface should be checked for damage and wear.
3. Always use the lubricant that is specified in the bolting chart. The bolt should not be lubricated before it is assembled in the flange connection.

5.5 Assembly

5.5.2 Bolts

4. The bolt's threads that engage with a nut should be lubricated on the side of the connection where the tool is installed. The bolt should also be lubricated on the other side.
5. Nuts are assembled correctly so that labeling is visible after assembly.
6. Nuts that are assembled with a wrench shall be lubricated on the contact surface towards the flange and on the first two threads near the flange. The bolt should also be lubricated on the other side.



7. The bolts should move freely through the opposite flange.

The friction in a screw connection is difficult to predict accurately since this is dependent on a long list of variable factors. Since most of the moment is directed at countering friction, it is important that the threads of the bolt and nut are checked and lubricated.

5.6 Tightening

Only approved tools should be used as listed in the bolting chart. If other tools are to be used, a new and approved bolting chart should be established.

If it is necessary to create special tools to tighten in tight spaces, this should be approved in agreement with the procedures of the operating company.

The following should be checked before the tool is used:

1. That the tool has valid calibration.
2. That the tool and equipment are in an acceptable condition before they are pressurized.
3. That tools and equipment are used in accordance with the supplier's recommendations.

The following safety steps should be taken when the tool is in use:

1. Maintain a safe distance from the tool while the tool is pressurized.
2. Do not attempt to hold or adjust the tool when it is in operation.
3. Do not leave the work-site with a pressurized tool.
4. Use a wire to secure loose tools with work at heights.



**See Appendix "Safety moments".*

5.6 Tightening

For NCF5 Compact use of a minimum of four tools simultaneously is recommended where there are more than 8 bolts in the flange connection.



If it is difficult to close the flange connection on the outer edge with the given force or moment in the bolting chart, it is recommended to first check that all bolts are lubricated as recommended.

If one or both flanges are connected to a very stiff pipe part or equipment mount, the resistance against closing the flange connection may be higher than it would normally be. Then place half of the number of tools diametrically against each other, in other words, so that four tools pull two and two neighboring bolts diametrically opposed to each other, for example.

Ref. different tightening procedures in "Appendix".



5.7 Follow-up Inspection

1. Check that there is at least 1 thread outside of the nut on each side of the bolt after tightening.
2. Check that the flange has closed.
3. Any deviation should be reported to a technical supervisor.
4. Sign “Activity and inspection schedule”.
5. Fill out and sign “wrench sheet” and hang this on the flange.

The supervisor for the assembly should fill out and sign “Activity and inspection schedule” after each time that the flanges are assembled and the bolt connections are tightened with the prescribed moment/tightening force.



5.7 Follow-up Inspection

Old markings on the flange should be removed, and a new label sheet should be hung on the flange connection.

If it is necessary to use force beyond what is specified in “Alignment” to align the flange before normal tightening procedures can be started, this should be stated in the marking field in “Activity and inspection schedule” by the technician doing the work. This applies to all types of flange and clamp connections. The deviation should be recorded in the company’s system for handling deviations.

If different persons have been responsible for assembly and final bolt tightening, both should have signed with date at the end of a job.



6.1 Flange and Gasket Type 6B	126-127
6.2 Disassembly	128-135
6.3 Inspection	136
6.4 Alignment	137
6.5 Installation	138-141
6.6 Tightening	142-143
6.7 Follow-up Inspection	144-147

6.1 Flange and Gasket

There are different types of clamp connections, for example Grayloc, Techlok, and Destec. The hubs can be both the traditional, “recessed” and the “streamline bore” design.

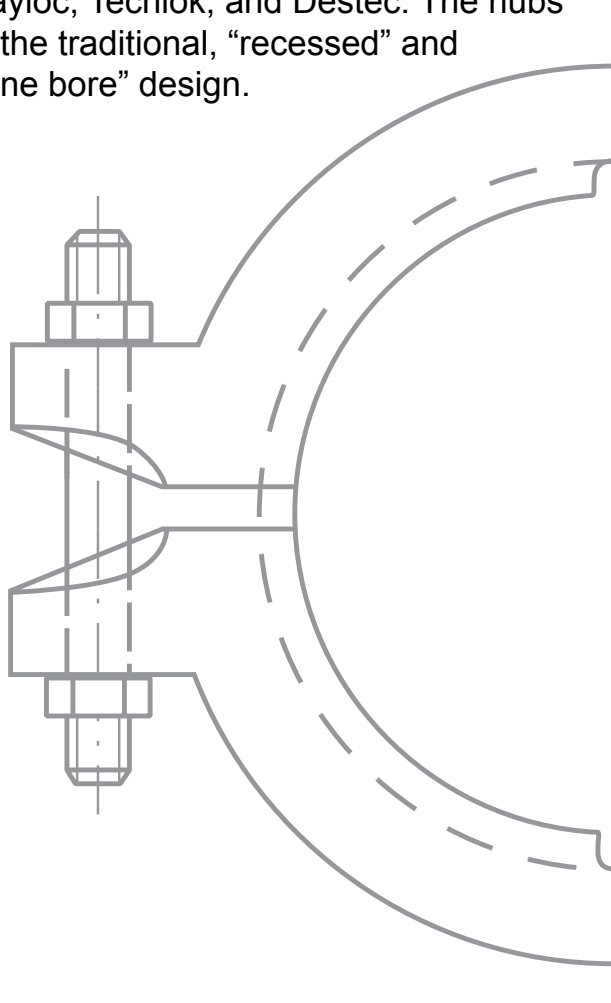

6.1 Flange and Gasket

The pipe clamp's design ensures that the sealing ring is clamped tight during assembly. The ring will be tight against the outer diameter against the hubs. The pressure from the media in the pipe will press the ring out and thereby provide better tightening the higher the pressure the application is exposed to.

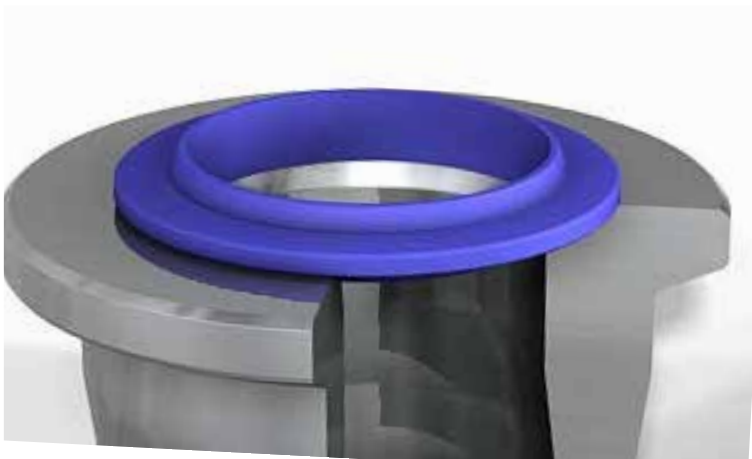

For clamp connections, the sealing ring is normally exposed to the media, and it is especially important to check that the label matches the bolting table or the pipe specification.

6.2 Disassembly

6.2.1 Phase 1 (loosen bolts)



Check that the safety declaration matches the work description. Am I working on the correct flange?



During disassembly, never assume that the line is depressurized. All flanges should be disassembled as if there is pressure in the system. The pressure build-up can occur for several reasons.

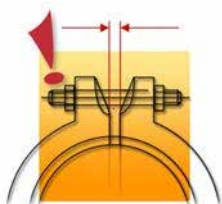

Check the distance between the clamps using a feeler gauge. If the distance is significantly less than what is specified, the clamp connection is probably overtightened and the clamps should be replaced. Report deviations to a technical supervisor and plan a remedy.



Check that the spring-loaded pipe supports are unloaded and placed in a locked position.

6.2 Disassembly

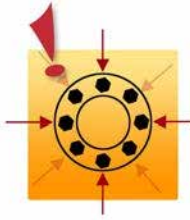

The bolts should be loosened according to the procedures in the section about avoiding uncontrolled tension in bolts and flanges.



CHECK THAT RELEVANT HSE PROCEDURES ARE FOLLOWED.

Hang necessary lifting equipment to ensure the responsible disassembly of clamps and any blind hub.



All deviations shall be logged in the “Activity and inspection schedule”, under “Notes” or on the back side.

6.2 Disassembly

6.2.1 Phase 1 (loosen bolts)

1. Use the maximum pump pressure for hydraulic wrenches.
2. It is recommended to use two tools diagonally during disassembly.*
3. Ensure that the tool has an appropriate counterhold. The counterhold keys shall be placed on the same bolts as the wrenches. The counterhold keys shall prevent the nuts from rotating during disassembly.
4. Loosen the bolts until there are a couple of millimeters clearance between the nuts and the clamps (see warning).



**For disassembly with hydraulic wrench tool: see Appendix – Tool use, Hydraulic wrench.*

6.2 Disassembly

6.2.1 Phase 1 (loosen bolts)

5. Repeat the operation gradually until the number of turns shown in table 6.1 is reached. The number of turns should be divided equally on both nuts.
6. Carefully tap the bolt with a suitable hammer so that it loosens.
7. Tap on the inside of the clamp's bolt collar until both clamps loosen.

NOTE!

The bolts and nuts should not be removed before the clamp is released and can freely rotate around the hub.



6.2 Disassembly

6.2.1 Phase 1 (loosen bolts)

Table 6.1

Hub	Number of turns 360 degrees	Opening in mm
2"	2	6 mm
3"	2.5	8 mm
4"	3.25	10 mm
6"	7	22 mm
8"	8	25 mm
10"	9.25	29 mm
12"	11.5	36 mm
14"	12.5	40 mm
H16	12.5	40 mm
H20	13.5	43 mm
H24	13	41 mm



NOTE! The torque wrench should not be used to remove bolts.

6.2 Disassembly

6.2.1 Phase 1 (loosen bolts)



Extra:

An 8" hub should have 4 turns per nut so that the total slack per bolt is 8 turns or 25 mm. The sealing ring now should be pressurized and the clamp should be free to rotate.

If the clamp can now rotate freely, further work with disassembling the clamp may continue.

6.2 Disassembly

6.2.2 Phase 2 (open connection)

**WARNING:**

If the clamp, after the number of turns is complete, cannot rotate freely around the hub, this indicates that there can be tension in the pipe system or that there is still pressure in the pipe. In this case, all further work should be stopped and a technical supervisor/system supervisor should be contacted.

Also be aware that any tension in the pipe system can be freed when someone tries to rotate the clamp.

There can be tension in the pipe that is first released when the sealing ring slips on one of the sides. Care should be shown during the removal of the clamps. It is recommended that you secure the pipe system in advance.

In cases where the sealing ring cannot be released when the clamps are removed, steps should be initiated to discharge the hub.

6.2 Disassembly

6.2.2 Phase 2 (open connection)



WARNING:

With disassembly of blind hubs, great care should be exercised. Never stand in front of blind hubs during disassembly.

6.3 Inspection



Immediately after the connection is disassembled and cleaned, it should be inspected. Additional inspection

personnel may be needed to perform an internal, visual inspection of pipes/hub and with welds between hub and pipe/equipment. If there is damage, this should be reported to a technical supervisor. Any tension in the pipe system should be reported to a technical supervisor.

Bolts and nuts should be checked for damage and the threads should be cleaned. Normally, galvanized bolts should not be reused.



If the flanges are not assembled immediately, the gasket surface should be protected.

Troubleshooting leaks



For more information about troubleshooting leaking flanges refer to: Appendix “Checklist for leaking flanges”.

6.4 Alignment

The hubs shall be set up in parallel for assembly of sealing rings and clamps. The hubs should be set up so that the lips of the sealing ring enter the light gasket surface on both hubs, and guide the hubs together in the correct way during the tightening of the bolts in the clamps.

Never try to correct a bad setup using a clamp/bolt tightening alone. Use hoists or other approved tool. Relevant temporary alignment with the help of hoists, etc. should first be removed when the clamps are finally assembled. The alignment forces to be used should be evaluated and approved by a technical supervisor.



6.5 Assembly

Before tightening flanges, be sure to thoroughly plan and prepare for the job in advance.

1. Seal surfaces on hubs should be checked for damage, corrosion and wear, and that the seal surface is free of coatings from painting and preservative. The clamp's contact surface against the nuts should also be free of any paint and preservative. Galvanizing or a thin layer with primer is permitted.
2. Clean seal surfaces. Steel brushes or approved emery paper may be used for this. Approved solvents and cloths may be used for final cleaning.
3. Do the cleaning along the seal surface. Ensure that the cleaning does not create radial tracks on the seal surface. You should pay careful attention to damage in a radial direction.

6.5 Assembly

6.5.1 Sealing ring

Clean and lubricate the contact surface between a hub and clamp with an approved lubricant, so that the clamp slides more easily into place during assembly.

Clamp connections are made from several types of materials. Therefore it is important to check the labeling on the sealing ring to be certain that both the material and quality are in accordance with the bolting chart.



6.5 Assembly

6.5.1 Sealing ring

1. Opening between the hubs should be larger than the thickness of the sealing ring so that this is not damaged during assembly.
2. A new sealing ring should always cover the clamp connections that have been opened.
3. Check that you have the correct sealing ring according to the table and that it is free of damage. The ring's size and material quality is marked on the ring.
4. Check that the ring sits correctly. It should be able to “rock” when it is placed in the hub. **Check against both the hubs!** It is also important to check that the sealing ring's collar lies parallel to the hub. The manufacturer of the hub may have created a table for how much the ring should be able to rock (Stand-off). Check this.
5. The sealing rings for clamp connections that are covered with Teflon (PTFE) should not be lubricated. In cases where the rings are not Teflon-coated, these are lubricated with a thin coating of Vaseline or thin machine oil.

6.5 Assembly

6.5.2 Bolts

The bolt's labeling is stamped on one end. The bolting chart provides information about the bolts, the type of bolt and nut material that should be used.



It includes a list of tools (for bolt diameters over 1"), number of bolts, bolt diameter, bolt length, key width, tightening force, the torque moment that the bolt should be tightened with, or A and B pressure if a hydraulic wrench equipment will be used. The bolting chart also indicates which type of lubrication should be used on bolts and nuts.

1. Nuts and bolts without markings should not be used.
2. The bolt's threads and the nut's contact surface should be checked for damage and wear.

6.6 Tightening

1. Always use the lubricant that is specified in the bolting chart.
2. The bolt should not be lubricated before it is assembled in the clamp.
3. The bolt's threads that engage with a nut should be lubricated on the side where the tool is installed. The bolt should also be lubricated on the other side.
4. Nuts are assembled correctly so that labeling is visible after assembly.
5. Nuts that are assembled with a wrench shall be lubricated on the contact surface towards the flange and on the first two threads near the flange. The bolt should also be lubricated on the other side.
6. The bolts should move freely through the opposite clamp.

The friction in a screw connection is difficult to predict accurately since this is dependent on a long list of variable factors. Since most of the moment is directed at countering friction, it is important that the threads of the bolt and nut are checked and lubricated.

6.6 Tightening

Between each tightening sequence, and before checking tightness, you should ensure that the clamps do not hang on the hub's conical contact surface. This can be done by tapping on the clamp with a suitable hammer.



Ref. different tightening procedures in "Appendix".



6.7 Follow-up Inspection

1. Check that the gap between the clamps is the same on both sides. This distance should be specified by the supplier.

The table below is an example:

CLAMP SIZE	1	1.5	2	3	4	6	XF	8
GAP A [mm]	6.4	9.6	9.6	9.6	9.6	15.8	12.0	19.4
CLAMP SIZE	X8	10H	X1CH	12M	X12M	A-P	S	U
GAP A [mm]	19.4	19.4	16.0	19.4	16.0	25.4	19.0	25.4
CLAMP SIZE	3V	3Y	X14	X16	X18	X20	X24	
GAP A [mm]	25.4	25.4	19.0	19.0	25.4	25.4	25.4	

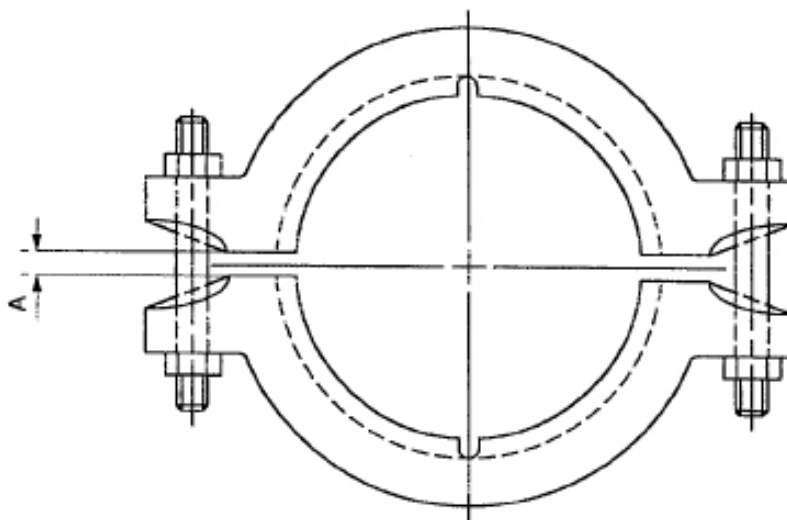

6.7 Follow-up Inspection

2. Sign “Activity and Inspection Schedule”.
3. Any deviation should be reported to a technical supervisor.
4. Fill out and sign “wrench sheet” and hang this on the flange.



6.7 Follow-up Inspection

The supervisor for assembly should fill out and sign “Activity and inspection schedule” after each time that the hubs are assembled and the bolt connections are tightened with the prescribed moment/tightening force.

5. Old markings should be removed, and a new label sheet should be hung on the clamp connection.

Check that the support ring on the sealing ring has contact with both the hubs. If there is a gap, the connection is not correctly assembled. Check that the distance between the clamps is correct in relation to the table from a supplier.

6. If it is necessary to use abnormally large forces to correct the hubs before normal tightening procedures can be started, this should be stated in the marking field in “Activity and inspection schedule” by the technician doing the work. The deviation should be recorded in the company’s system for handling deviations.
7. If different persons have been responsible for assembly and final bolt tightening, both should have signed with date at the end of a job.



Clamp
Connections

7.1 Safety Moment, locking pin/locking disk	150-151
7.2 Tool Use	152-163
7.3 Bolt Tables	164-166
7.4 Tables ASME RTJ, gap	168-171
7.5 Tables API 6A Type 6B, gap	172-173
7.6 Spring Supports	174-200
7.7 Checklist for Leaking Flanges	201-203
7.8 Example of Tightening Sheet	204-205
7.9 Example of Activity Inspection Schedule	206-207
7.10 Version changes	208-208

7.1 Safety Moments

7.1.1 Locking pin



When working at assigned locations or at heights, additional safety pins should be inserted between tools and parts as shown.

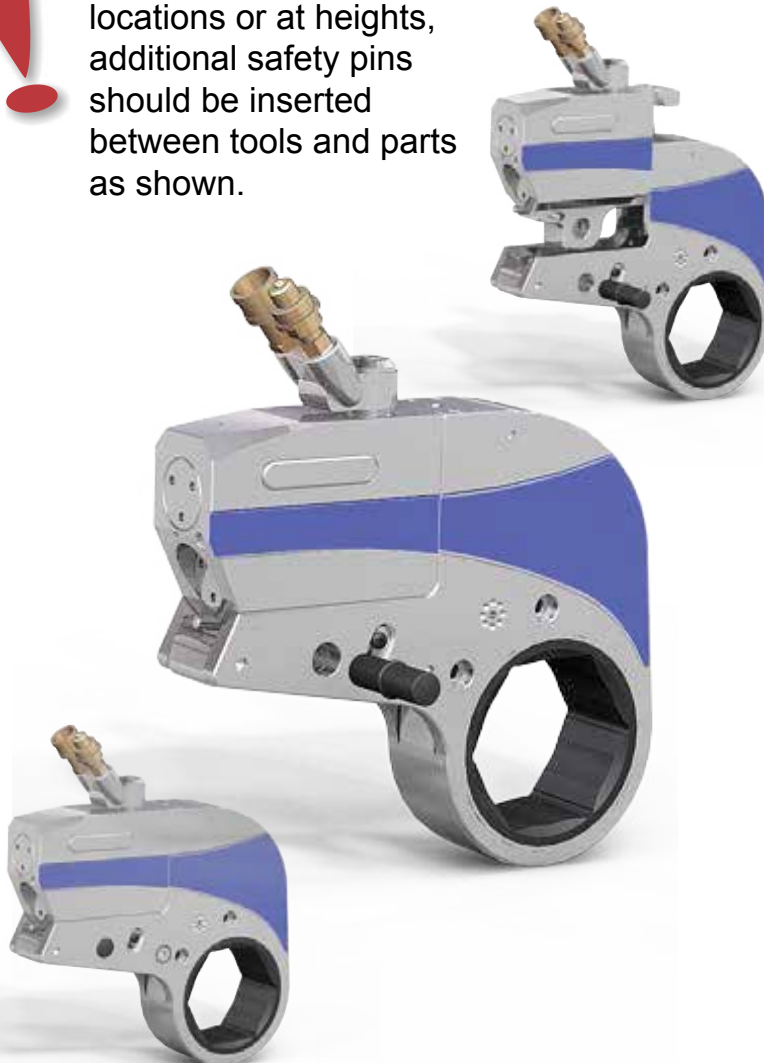

7.1 Safety Moments

7.1.2 Locking disk

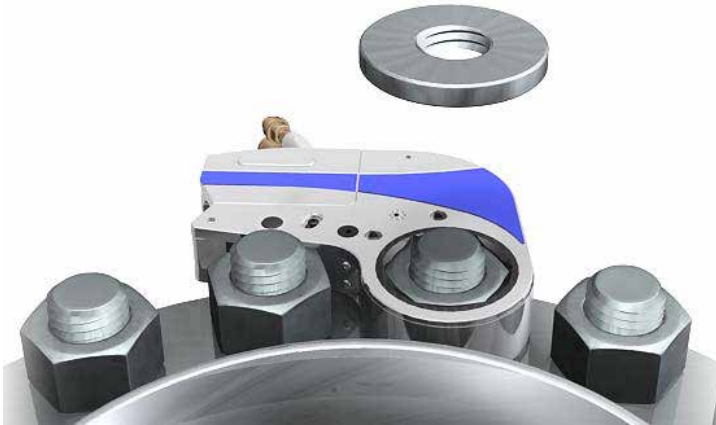

When working on flanges, where there is a need to grip or hold onto the tool, a locking disk should be installed to prevent clamp damage. For example where the tools have to be installed on the underside of the flange.

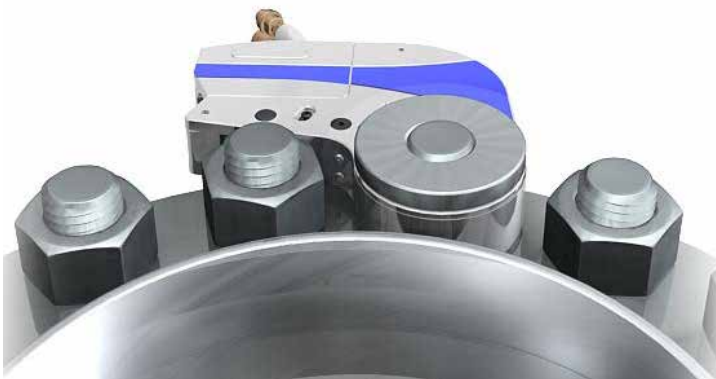

7.2 Tool Use

7.2.1 Loosen bolts, hydraulic wrench

1. Use the maximum pump pressure for hydraulic wrenches. It is recommended that you use four tools during disassembly.
2. Ensure that the tool has an appropriate counterhold.
3. The counterhold keys shall be placed on the same bolts as the wrenches.
4. The counterhold keys shall prevent the nuts from rotating during disassembly.

Install the equipment and check it as described for tightening. Set the pump for maximum pressure.

7.2 Tool Use

7.2.1 Loosen bolts, hydraulic wrench

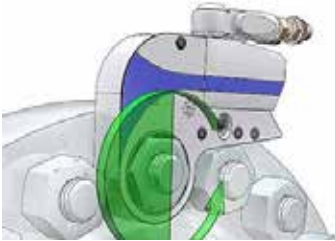

RTJ, RF/FF, API 6A

Loosen 1/2 of a turn at a time. Follow the procedure for cross wrenching, until the tension is taken off the bolts.



NCF5

Loosen 1/6th of a turn at a time. Follow the procedure for cross wrenching, until the tension is taken off the bolts.

Loosen the bolts until there are a couple of millimeters clearance between the nuts and the flange. Carefully hit the flange with a hammer so that the gasket loosens.

7.2 Tool Use

7.2.2 Loosen bolts, hydraulic wrench

Normally it is easiest to use a tool to loosen bolts. Perform the disassembly in a cross direction.



Assemble the tool with a 3 mm light opening between the wrench and the cylinder.



Pressurize the tool slowly until the nut can be unscrewed from the bolt. Turn the nut a 1/2 time around. Repeat the operation until all of the nuts are loosened.



Alternatively, the tool may be installed as described under the assembly. Pressurize the tool slowly until the bolts loosen.

7.2 Tool Use

7.2.3 Tighten bolts, hand tool

In accordance with NORSOK L-004, torque wrenches may be used for bolt sizes up to and including 1". Check that the tool's calibration is valid with respect to ISO 6789 and ISO/IEC 17025.

Use a torque wrench if a hydraulic tool isn't appropriate. To avoid deformation in the spring, the key should always be reset after use – this does not apply to Stahlwille keys as shown. Follow guidelines from the supplier of the torque wrench.



7.2 Tool Use

7.2.4 Tighten bolts, hydraulic wrench



7.2 Tool Use

7.2.4 Tighten bolts, hydraulic wrench

Tightening procedure with 1 tool

1. 1 revolution across with 30% of the given moment.
2. 1 revolution across with 60% of the given moment.
3. 2 revolutions across with 100% of the given moment.
4. After the last tightening, all bolts should be checked with full moment.
5. Do checks in a clockwise direction.

This procedure also applies for use of a torque wrench.



Tightening procedure with 2 tools

1. 1 revolution across with 50% of the given moment.
2. 2 revolutions across with 100% of the given moment.
3. After the last tightening, all bolts should be checked with full moment.
4. Do checks in a clockwise direction.

Tightening procedure with 4 tools

1. Tighten all bolts with the given moment in the bolting chart 2 times.
2. Check that the tools are placed crosswise at all times.
3. After the last tightening, all bolts should be checked with full moment.
4. Do checks in a clockwise direction.

7.2 Tool Use

7.2.5 Tighten bolts, hydraulic wrench

1. Check that the bolt extension beyond the nut is no longer than the bolt's diameter.
2. Place a cap over nuts.



3. Check the tool size with a bolting table.
4. Assemble bridge and hydraulic head.



5. Assemble the wrench cap. The tool is installed on each bolt around the entire flange.



6. Connect the hydraulic hoses. Check that all quick connections are properly connected together.



7.2 Tool Use

7.2.5 Tighten bolts, hydraulic wrench

7. Pressurize the tools with A-pressure given in the bolting chart.
8. Screw down nuts with a Tommy bar.
9. Turn off pressure and screw down the wrench cap. Screw the cylinder back with the wrench cap.
10. Repeat points 7, 8 and 9 three times or until the nuts have seated themselves.
11. Move the tools over to the next bolt set. Pressurize with B-pressure, given in the bolting chart and follow the same procedure as for A-pressure.
12. Check release pressure. Place a minimum of two tools on the first bolt set and increase the pressure to B-pressure. If the bolts loosen before this pressure is reached, the entire tightening procedure will have to be done again.



7.2 Tool Use

7.2.6 Tighten bolts, mechanical wrench, procedure for Stealth and LoaDisc

1. Assemble the bolts in the flange. Assemble LoaDisc on the side the tool is installed, and normal nuts on the opposite side. After LoaDisc is installed, there should be a bolt extension of about one bolt diameter. If it does not need a counterhold, there is no pinch danger.

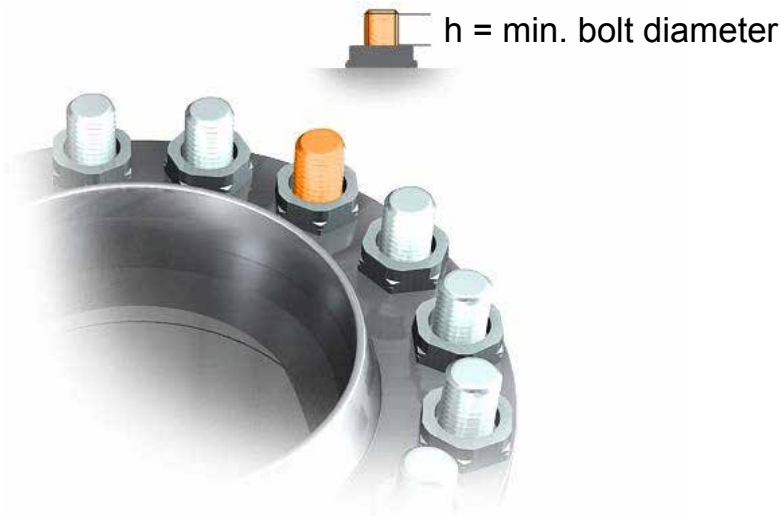

2. Lubricate the bolt's threads and the contact surface of the nut with an even layer of the given lubricant. Assemble the last nuts, so that LoaDisc is an underlay, between the nuts and flange on the side where the tool is installed.

7.2 Tool Use

7.2.6 Tighten bolts, mechanical wrench, procedure for Stealth and LoaDisc

3. Tighten the flanges:
 - 3.1 Install the tools in a cross and set the pump to 100% of the given pump pressure. Use the bolting table for LoaDisc. Follow standard tightening procedure.



- 3.2 Install the tools on any bolt and tighten with 100% of the given pump pressure. Use the bolting table for LoaDisc. Follow standard tightening procedure.



7.2 Tool Use

7.2.7 Tighten bolts, mechanical wrench, procedure for Avanti and ClampNut

1. Assemble the bolts in the flange. Lubricate the bolt's threads on the side where ClampNut is installed. Install Hytorc ClampNut. Ensure that all threads are engaged. The bolt should also be lubricated on the other side.

If it does not need a counterhold, there is no pinch danger.



7.2 Tool Use

7.2.7 Tighten bolts, mechanical wrench, procedure for Avanti and ClampNut

2. Tighten the flanges:
 - 2.1 Install the tools on any bolt and tighten with 100% of the given pump pressure. Use a bolting chart for ClampNut. Follow standard tightening procedure.
 - 2.2 Install the tools on all the bolts and tighten with 100% of the given pump pressure. Use a bolting chart for ClampNut. Follow standard tightening procedure.



7.3 Bolt Tables

Flange PN inch		ISO PN 20 - ASME Class 150					ISO PN 50 - ASME Class 300				
		Bolts					Bolts				
		number	bolt dia.	nut dia.	bolt dia.	nut	number	bolt dia.	nut dia.	bolt dia.	nut
15	1/2"	4	14	22	1/2"	7/8"	4	14	22	1/2"	7/8"
20	3/4"	4	14	22	1/2"	7/8"	4	16	24	5/8"	1-1/16"
25	1"	4	14	22	1/2"	7/8"	4	16	24	5/8"	1-1/16"
32	1-1/4"	4	14	22	1/2"	7/8"	4	16	24	5/8"	1-1/16"
40	1-1/2"	4	14	22	1/2"	7/8"	8	20	30	3/4"	1-1/4"
50	2"	4	16	24	5/8"	1-1/16"	8	16	24	5/8"	1-1/16"
65	2-1/2"	4	16	24	5/8"	1-1/16"	8	20	30	3/4"	1-1/4"
80	3"	4	16	24	5/8"	1-1/16"	8	20	30	3/4"	1-1/4"
90	3-1/2"	8	16	24	5/8"	1-1/16"	8	20	30	3/4"	1-1/4"
100	4"	8	16	24	5/8"	1-1/16"	8	20	30	3/4"	1-1/4"
125	5"	8	20	30	3/4"	1-1/4"	8	20	30	3/4"	1-1/4"
150	6"	8	20	30	3/4"	1-1/4"	12	20	30	3/4"	1-1/4"
200	8"	8	20	30	3/4"	1-1/4"	12	24	36	7/8"	1-7/16"
250	10"	12	24	36	7/8"	1-7/16"	16	27	41	1"	1-5/8"
300	12"	12	24	36	7/8"	1-7/16"	16	30	46	1-1/8"	1-13/16"
350	14"	12	27	41	1"	1-5/8"	20	30	46	1-1/8"	1-13/16"
400	16"	16	27	41	1"	1-5/8"	20	33	50	1-1/4"	2"
450	18"	16	30	46	1-1/8"	1-13/16"	24	33	50	1-1/4"	2"
500	20"	20	30	46	1-1/8"	1-13/16"	24	33	50	1-1/4"	2"
600	24"	20	33	50	1-1/4"	2"	24	33	50	1-1/4"	2"
650	26"	24	33	50	1-1/4"	2"	28	42	65	1-5/8"	2-9/16"
700	28"	28	33	50	1-1/4"	2"	28	42	65	1-5/8"	2-9/16"
750	30"	28	33	50	1-1/4"	2"	28	45	70	1-3/4"	2-3/4"
800	32"	28	39	60	1-1/2"	2-3/8"	28	48	75	1-7/8"	2-15/16"
850	34"	32	39	60	1-1/2"	2-3/8"	28	48	75	1-7/8"	2-15/16"
900	36"	32	39	60	1-1/2"	2-3/8"	32	52	80	2"	3-1/8"
950	38"	32	39	60	1-1/2"	2-3/8"	32	39	60	1-1/2"	2-3/8"
1,000	40"	36	39	60	1-1/2"	2-3/8"	32	42	65	1-5/8"	2-9/16"
1,050	42"	36	39	60	1-1/2"	2-3/8"	32	42	65	1-5/8"	2-9/16"
1,100	44"	40	39	60	1-1/2"	2-3/8"	32	45	70	1-3/4"	2-3/4"
1,150	46"	40	39	60	1-1/2"	2-3/8"	28	48	75	1-7/8"	2-15/16"
1,200	48"	44	39	60	1-1/2"	2-3/8"	32	48	75	1-7/8"	2-15/16"

7.3 Bolt Tables

Flange PN inch		ISO PN 100 - ASME Class 600					ISO PN 150 - ASME Class 900				
		Bolts					Bolts				
		number	bolt dia.	nut dia.	bolt dia.	nut	number	bolt dia.	nut dia.	bolt dia.	nut
15	1/2"	4	14	22	1/2"	7/8"	4	20	30	3/4"	1-1/4"
20	3/4"	4	16	24	5/8"	1-1/16"	4	20	30	3/4"	1-1/4"
25	1"	4	16	24	5/8"	1-1/16"	4	24	36	7/8"	1-7/16"
32	1-1/4"	4	16	24	5/8"	1-1/16"	4	24	36	7/8"	1-7/16"
40	1-1/2"	8	20	30	3/4"	1-1/4"	4	27	41	1"	1-5/8"
50	2"	4	16	24	5/8"	1-1/16"	8	24	36	7/8"	1-7/16"
65	2-1/2"	8	20	30	3/4"	1-1/4"	8	27	41	1"	1-5/8"
80	3"	8	20	30	3/4"	1-1/4"	8	24	36	7/8"	1-7/16"
90	3-1/2"	8	24	36	7/8"	1-7/16"					
100	4"	8	24	36	7/8"	1-7/16"	8	30	46	1-1/8"	1-13/16"
125	5"	8	27	41	1"	1-5/8"	8	33	50	1-1/4"	2"
150	6"	12	27	41	1"	1-5/8"	12	30	46	1-1/8"	1-13/16"
200	8"	12	30	46	1-1/8"	1-13/16"	12	36	55	1-3/8"	2-3/16"
250	10"	16	33	50	1-1/4"	2"	16	36	55	1-3/8"	2-3/16"
300	12"	20	33	50	1-1/4"	2"	20	36	55	1-3/8"	2-3/16"
350	14"	20	36	55	1-3/8"	2-3/16"	20	39	60	1-1/2"	2-3/8"
400	16"	20	39	60	1-1/2"	2-3/8"	20	42	65	1-5/8"	2-9/16"
450	18"	20	42	65	1-5/8"	2-9/16"	20	48	75	1-7/8"	2-15/16"
500	20"	24	42	65	1-5/8"	2-9/16"	20	52	80	2"	3-1/8"
600	24"	24	33	50	1-1/4"	2"	20	64	95	2-1/2"	3-7/8"
650	26"	28	42	65	1-5/8"	2-9/16"	20	68	100	2-3/4"	4-1/4"
700	28"	28	42	65	1-5/8"	2-9/16"	20	76	110	3"	4-5/8"
750	30"	28	45	70	1-3/4"	2-3/4"	20	76	110	3"	4-5/8"
800	32"	28	48	75	1-7/8"	2-15/16"	20	80	115	3-1/4"	5"
850	34"	28	48	75	1-7/8"	2-15/16"	20	90	130	3-1/2"	5-3/8"
900	36"	28	52	80	2"	3-1/8"	20	90	130	3-1/2"	5-3/8"
950	38"	28	39	60	1-1/2"	2-3/8"	20	90	130	3-1/2"	5-3/8"
1,000	40"	32	42	65	1-5/8"	2-9/16"	24	90	130	3-1/2"	5-3/8"
1,050	42"	28	42	65	1-5/8"	2-9/16"	24	90	130	3-1/2"	5-3/8"
1,100	44"	32	45	70	1-3/4"	2-3/4"	24	95	135	3-3/4"	5-3/4"
1,150	46"	32	48	75	1-7/8"	2-15/16"	24	100	145	4"	6-1/8"
1,200	48"	32	48	75	1-7/8"	2-15/16"	24	100	145	4"	6-1/8"

7.3 Bolt Tables

Flange		ISO PN 250 - ASME Class 1500					ISO PN 420 - ASME Class 2500				
PN	inch	Bolts					Bolts				
		number	bolt dia.	nut dia.	bolt dia.	nut	number	bolt dia.	nut dia.	bolt dia.	nut
15	1/2"	4	20	30	3/4"	1-1/4"	4	20	30	3/4"	1-1/4"
20	3/4"	4	20	30	3/4"	1-1/4"	4	20	30	3/4"	1-1/4"
25	1"	4	24	36	7/8"	1-7/16"	4	24	36	7/8"	1-7/16"
32	1-1/4"	4	24	36	7/8"	1-7/16"	4	27	41	1"	1-5/8"
40	1-1/2"	4	27	41	1"	1-5/8"	4	30	46	1-1/8"	1-13/16"
50	2"	8	24	36	7/8"	1-7/16"	8	27	41	1"	1-5/8"
65	2-1/2"	8	27	41	1"	1-5/8"	8	30	46	1-1/8"	1-13/16"
80	3"	8	30	46	1-1/8"	1-13/16"	8	33	50	1-1/4"	2"
90	3-1/2"										
100	4"	8	33	50	1-1/4"	2"	8	39	60	1-1/2"	2-3/8"
125	5"	8	39	60	1-1/2"	2-3/8"	8	45	70	1-3/4"	2-3/4"
150	6"	12	36	55	1-3/8"	2-3/16"	8	52	80	2"	3-1/8"
200	8"	12	42	65	1-5/8"	2-9/16"	12	52	80	2"	3-1/8"
250	10"	12	48	75	1-7/8"	2-15/16"	12	64	95	2-1/2"	3-7/8"
300	12"	16	52	80	2"	3-1/8"	12	68	100	2-3/4"	4-1/4"
350	14"	16	56	85	2-1/4"	3-1/2"					
400	16"	16	64	95	2-1/2"	3-7/8"					
450	18"	16	68	100	2-3/4"	4-1/4"					
500	20"	16	76	110	3"	4-5/8"					
600	24"	16	90	130	3-1/2"	5-3/8"					
650	26"										
700	28"										
750	30"										
800	32"										
850	34"										
900	35"										
950	38"										
1,000	40"										
1,050	42"										
1,100	44"										
1,150	46"										
1,200	48"										

7.3 Bolt Tables

Bolts ASTM A 193 - A 320 Nuts A 194 4 and 7						
Inches				Metric		
Bolts Size	Thread pitch	Nut size		Bolts Size	Thread pitch	Nut size
		Inch	mn.			
3/8"	16	11/16"	17.5	M3	1.25	13
7/16"	14	3/4"	19	M10	1.5	17
1/2"	13	7/8"	22.2	M12	1.75	19
9/16"	12	15/16"	23.8	M14	2	22
5/8"	11	1-1/16"	27	M16	2	24
3/4"	10	1-1/4"	31.7	M18	2.5	27
7/8"	9	1-7/16"	36.5	M20	2.5	30
1"	8	1-5/8"	41.3	M22	2.5	32
1-1/8"	8	1-13/16"	46	M24	3	36
1-1/4"	8	2"	50.8	M27	3	41
1-3/8"	8	2-3/16"	55.6	M30	3.5 or 3.0	46
1-1/2"	8	2-3/8"	60.3	M33	3.5 or 3.0	50
1-5/8"	8	2-9/16"	65.1	M36	4.0 or 3.0	55
1-3/4"	8	2-3/4"	69.8	M39	4.0 or 3.0	60
1-7/8"	8	2-15/16"	74.6	M42	4.5 or 3.0	65
2"	8	3-1/8"	79.4	M45	4.5 or 3.0	70
2-1/4"	8	3-1/2"	88.9	M48	5.0 or 3.0	75
2-1/2"	8	3-7/8"	98.4	M52	5.0 or 3.0	80
2-3/4"	8	4-1/4"	108	M56	5.5 or 4.0	85
3"	8	4-5/8"	117.5	M60	6.0 or 4.0	90
3-1/4"	8	5"	127	M64	6.0 or 4.0	95
3-1/2"	8	5-3/8"	136.5	M68	6.0 or 4.0	100
3-3/4"	8	5-3/4"	146	M72	6.0 or 4.0	105
4"	8	6-1/8"	155.6	M76	6.0 or 4.0	110
				M80	6.0 or 4.0	115
				M85	6.0 or 4.0	120
				M90	6.0 or 4.0	130
				M95	6.0 or 4.0	135
				M100	6.0 or 4.0	145

7.4 Tables ASME RTJ, gap

Nominal diameter [inches]						
Class 150 NPS	Class 300 NPS	Class 400 NPS	Class 600 NPS	Class 900 NPS	Class 1500 NPS	Class 2500 NPS
	1/2		1/2			
	3/4		3/4		1/2	1-1/2 or 1/2
1					3/4	
1-1/4	1		1		1	3/4
1-1/2	1-1/4		1-1/4		1-1/4	1
	1-1/2		1-1/2		1-1/2	
2						1-1/4
	2		2			1-1/2
2-1/2					2	
	2-1/2		2-1/2			2
					21.2	2-1/2
3						
	3 (2)		(2)			
	3 (2)		(2)	3		3
3-1/2						
	3-1/2		3-1/2			
4					3	
	4	4	4	4		4
					4	
5						
	5	5	5	5		5
6					5	
	6	6	6	6		
					6	
8						6
	8	8	8	8		

7.4 Tables ASME RTJ, gap

Approximate distance between flanges inside with a sealing ring [mm]						
Class 150	Class 300	Class 400	Class 600	Class 900	Class 1500	Class 2500
	3		3			
	4		4		4	4
					4	
4	4		4		4	4
4	4		4		4	4
4	4		4		4	4
	4		4		4	3
4	6		5			3
					3	
4	6		5			3
					3	
4						3
	6		5	4		
4						3
	6		5		3	
4						3
	6	6	5	4		4
					3	
4						4
	6	6	5	4		
4					3	
	6	6	5	4	3	
						4
4					3	
	6	6	5	4	3	
						4
4						
	6	6	5	4		

**Example**

Class 150 NPS 4:
The flange connection has a nominal gap of 4 mm.

Explanation

Class: Pressure rating NPS 4: 4" flange

7.4 Tables ASME RTJ, gap

Nominal diameter [inches]						
Class 150 NPS	Class 300 NPS	Class 400 NPS	Class 600 NPS	Class 900 NPS	Class 1500 NPS	Class 2500 NPS
					8	8
10	10	10	10	10	10	10
12	12	12	12	12	12	12
14	14	14	14	14	14	14
16	16	16	16	16	16	16
18	18	18	18	18	18	18
20	20	20	20	20	20	20
24	24	24	24	24	24	24

7.4 Tables ASME RTJ, gap

Approximate distance between flanges inside with a sealing ring [mm]						
Class 150	Class 300	Class 400	Class 600	Class 900	Class 1500	Class 2500
					4	5
4	6	6	5	4	4	6
4	6	6	5	4	5	
3	6	6	5			8
				4	6	
3	6	6	5	4		
					8	
3	6	5	5	5		
					8	
3	6	6	5	5		
					10	
3	6	6	6	6		
					11	



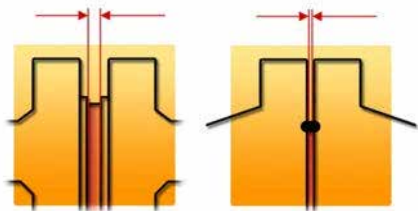

7.5 Tables API 6A Type 6B, gap



Type R ring seal		Type RX ring seal	
Ring number	Approximate distance between assembled flanges [mm]	Ring number	Approximate distance between assembled flanges [mm]
R20	4.1	RX20	9.7
R23	4.8	RX23	11.9
R24	4.8	RX24	11.9
R26	4.8	RX25	-
R27	4.8	RX26	
		RX27	11.9
R31	4.8	RX31	11.9
R35	4.8	RX35	11.9
R37	4.8	RX37	11.9
R39	4.8	RX39	11.9
R41	4.8		
		RX41	11.9
R44	4.8	RX44	11.9
R45	4.8	RX45	11.9
R46	4.8	RX46	11.9
R47	4.1	RX47	23.1
R49	4.8	RX49	11.9
R50	4.1	RX50	11.9
R53	4.8	RX53	11.9
R54	4.1	RX54	11.9
R57	4.8	RX57	11.9

7.5 Tables API 6A Type 6B, gap

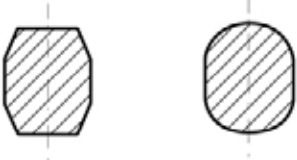
>> continued from page 172

Type R ring seal		Type RX ring seal	
			
Ring number	Approximate distance between assembled flanges [mm]	Ring number	Approximate distance between assembled flanges [mm]
R63	5.6	RX63	21.3
R65	4.8	RX65	11.9
R66	4.1	RX66	11.9
R69	4.8	RX69	11.9
R70	4.8	RX70	18.3
R73	3.3	RX73	15.0
		RX74	18.3
R74	4.8	RX82	11.9
R82	4.8	RX84	11.9
R84	4.8	RX85	9.7
R85	3.3		
R86	4.1	RX86	9.7
		RX87	9.7
R87	4.1	RX88	9.7
R88	4.8	RX89	9.7
R89	4.8	RX90	18.3
R90	4.8	RX91	19.1
R91	4.1	RX99	11.9
R99	4.8	RX201	-
		RX205	-
		RX210	-
		RX215	-

7.6 Spring Supports

This section is for information only.

7.6.1 Pipe support with springs

A pipe system is affected by several different forces:

- Temperature
- Pressure
- Flow forces
- Imposed deformations
- Wind
- Explosion
- Etc.



7.6 Spring Supports

To withstand these influences, a pipe system must be constructed in a controlled way. The goal with the construction is that the system shall be fixed at individual points, but it is allowed to shift at other points. It is especially important to avoid trapped tension forces because of either temperature or deformations suffered.

In some cases it is difficult to achieve a construction that ensures that the pipe is not overloaded because of weight, at the same time that you avoid trapped tension forces because of temperature or deformation. In such cases springs are often used (“spring supports”).

7.6 Spring Supports

7.6.2 Objective with springs

Springs are often used in situations where spigots on the equipment are involved. A spigot on a tank, pump, compressor or the like has a limited capacity to absorb the forces from the pipe system. Therefore, a pipe support should normally be installed in the immediate vicinity of the spigot to unload this.

In an ideal world without movement of these spigots or thermal expansion of the pipe, a normal pipe support would be enough to let this be. In practice, the situation is often that the spigot, temporarily, moves in relation to the pipe system's other pipe supports. This is caused because the equipment has a thermal expansion between its fixed point and the spigot.

7.6 Spring Supports

7.6.2 Objective with springs

With a tank with a diameter of 5 m and the spigot to the pipe system placed on the top of the tank, this spigot will move about 6 mm vertically if the tank has a temperature variation of 100°C.

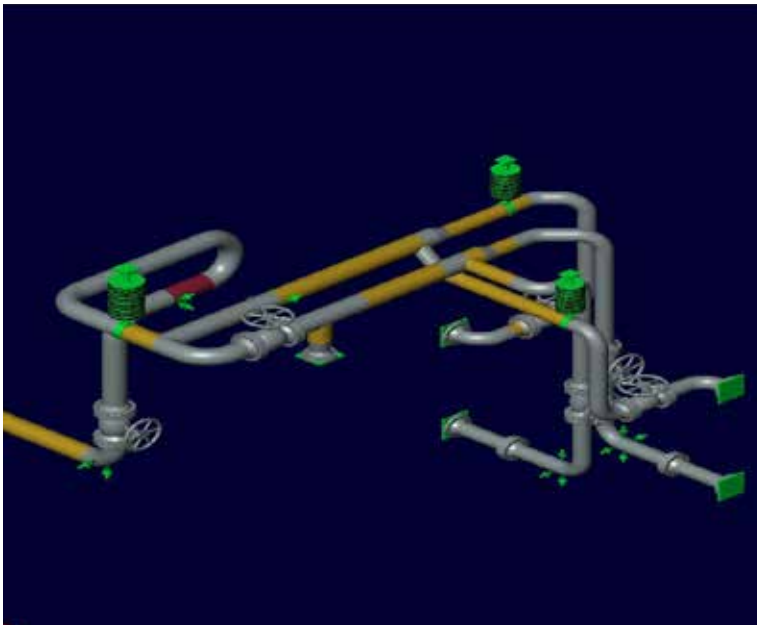

Figure 1.

7.6 Spring Supports

7.6.2 Objective with springs

If a normal “rest-support” (fixed pipe support) had been installed in the neighborhood of the spigot, the pipe will only lift from this pipe support when the tank became hot. (See figures 2 and 3.) If the tank was cooled, the pipe will be pressed down against the pipe support/beam and there could be large imposed forces.

If the pipe support is replaced with a flexible element (see figure 3) like a spring, the majority of the pipe’s weight will be borne by the spring. The spring will “follow” the tank’s movement when it is exposed to temperature changes.

7.6 Spring Supports

7.6.2 Objective with springs

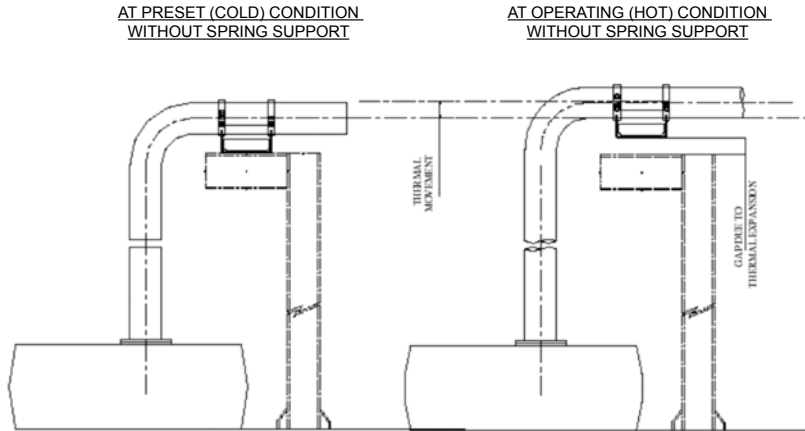

Figure 2.

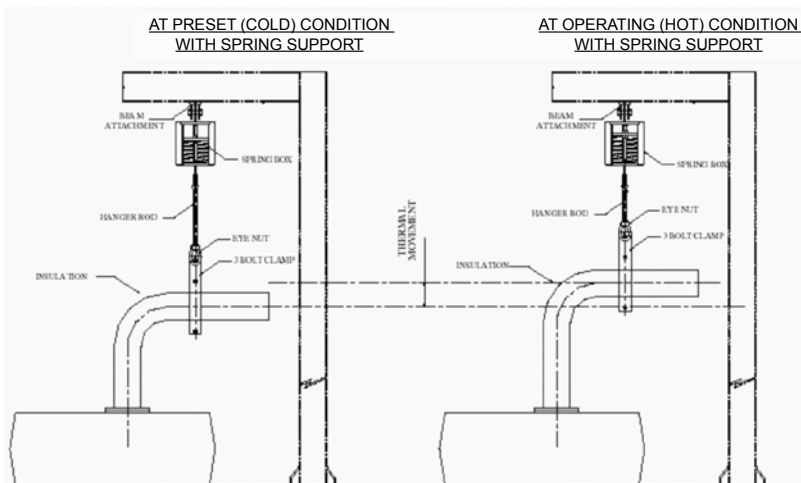

Figure 3.

7.6 Spring Supports

7.6.3 Variable springs

The simplest spring type is a so-called variable spring. It is normally a device based on a coil spring. Such a spring is characterized by three parameters:

- Tension
- Spring constant
- Permitted movement

The spring is delivered in different models where the springs have different lengths, diameters and thickness to achieve the desired parameters. The spring constant is fixed for a concrete spring, but it is possible to change the tension to a certain degree by adjusting the spring.

Normally, a variable spring is constructed as shown in figure 4, 5 and 6.

7.6 Spring Supports

7.6.3 Variable springs

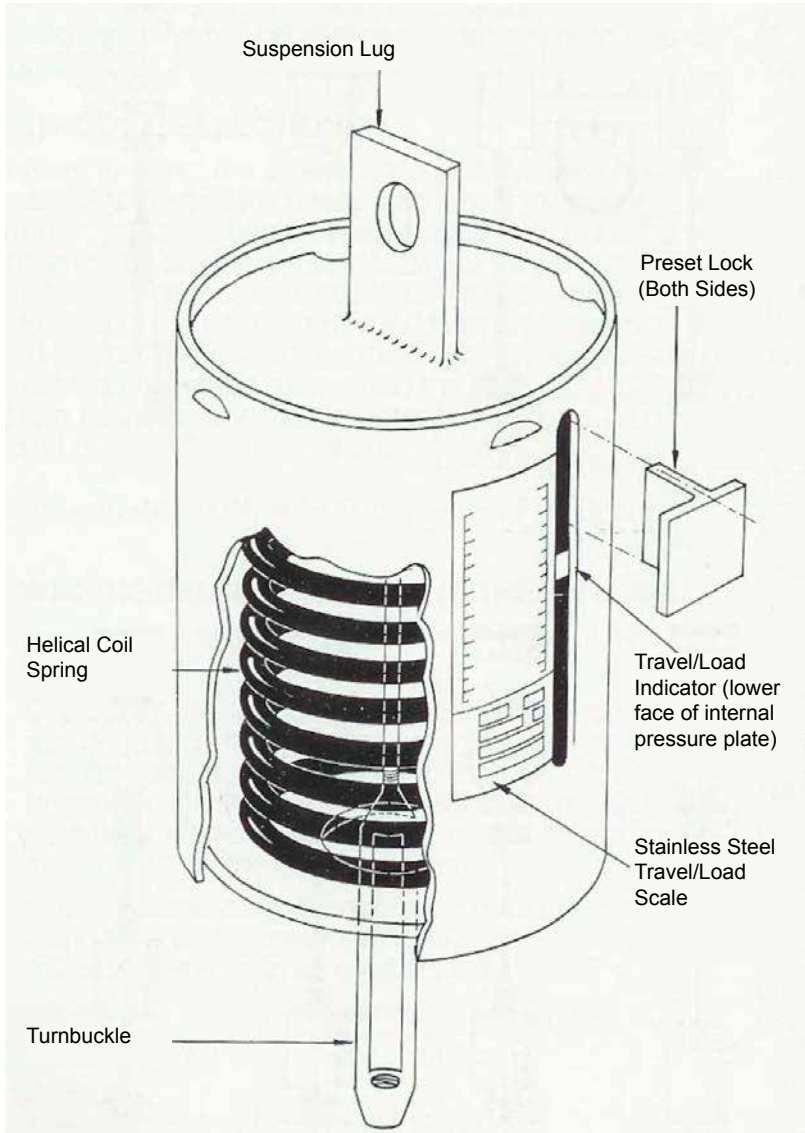

Figure 4.

7.6 Spring Supports

7.6.3 Variable springs

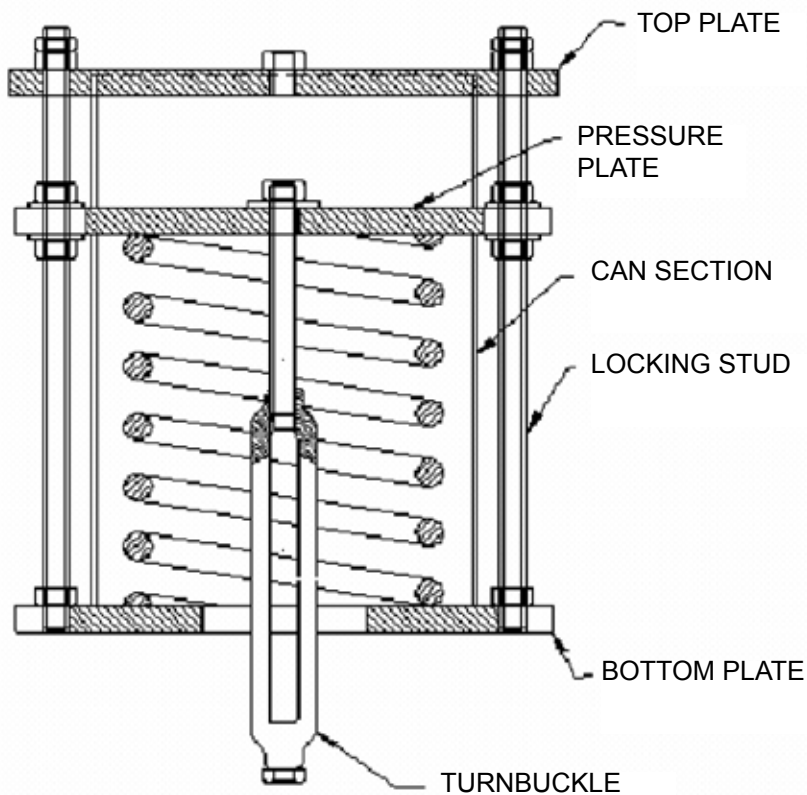

Figure 5.

7.6 Spring Supports

7.6.3 Variable springs

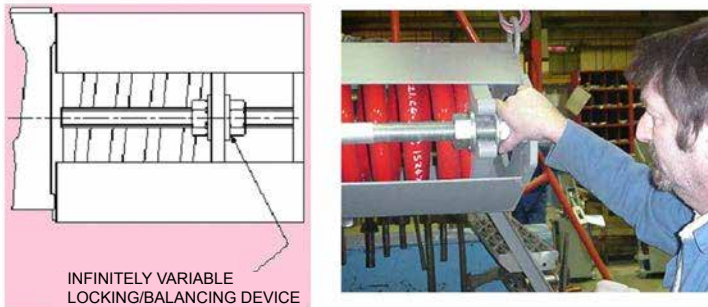

Figure 6.

The actual coil spring is inside a cylinder. A circular plate over the spring is bound with a steel post that transfers the force from the pipe.

Some springs have a sliding track in the cylinder so that the plate can be locked in a specific position which corresponds to the correct tension. (See figure 4.) The locking plate is not removed as it should be when the pipe system is put in operation. (See figure 8.)

Other springs use lock nuts. (See figures 5 and 6.)

7.6 Spring Supports

7.6.3 Variable springs

When the springs come from the supplier, the spring is pressed together corresponding to the correct tension, and there are metal pieces inserted that lock the plate in this position. This is done to simplify correct installation of the spring. (See figure 4.)

For spring types that use locking nuts, you can check if the spring has the correct load by trying to rotate the locking nuts on one or another side of the spring plate. If there is significant resistance, the spring is not correctly installed and adjusted. Adjustment is done by turning on the turnbuckle, for example (turnbuckle). (See figures 5, 10 and 11.)

The sliding track is labeled with a scale so that you can read the spring forces by looking where the plate over the spring lies in relation to the scale. From the scale you can also tell how much movement the spring allows in each direction. (See figures 7 and 9.)

7.6 Spring Supports

7.6.3 Variable springs



Figure 7.



Figure 8.

7.6 Spring Supports

7.6.3 Variable springs

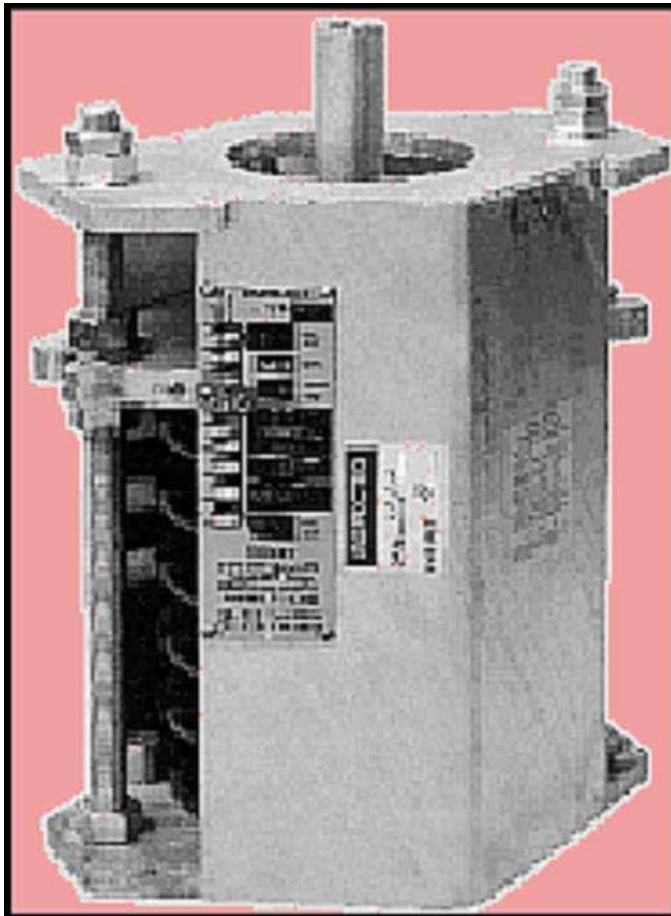

Figure 9.

7.6 Spring Supports

7.6.3 Variable springs

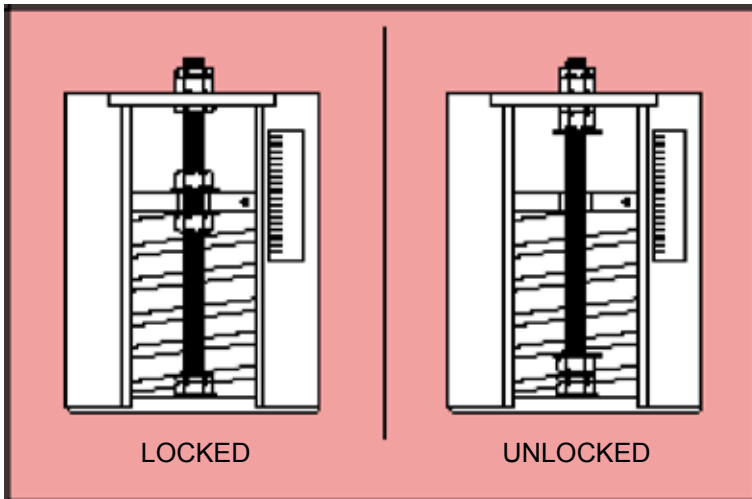

Figure 10.

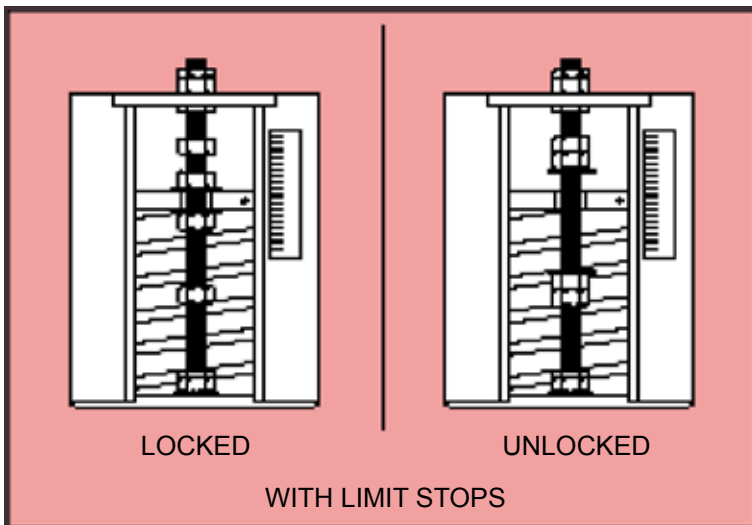

Figure 11.

7.6 Spring Supports

7.6.4 Constant springs

In some connections it is not acceptable that the construction forces vary with the pipe's movement. This often applies to a connection with a spigot on sensitive equipment combined with large movements.

In such cases, constant springs are often used. These are devices that provide a nearly constant support force. In its simplest configuration, this can be as simple as a weight on a pulley that provides a constant force.

7.6 Spring Supports

7.6.4 Constant springs

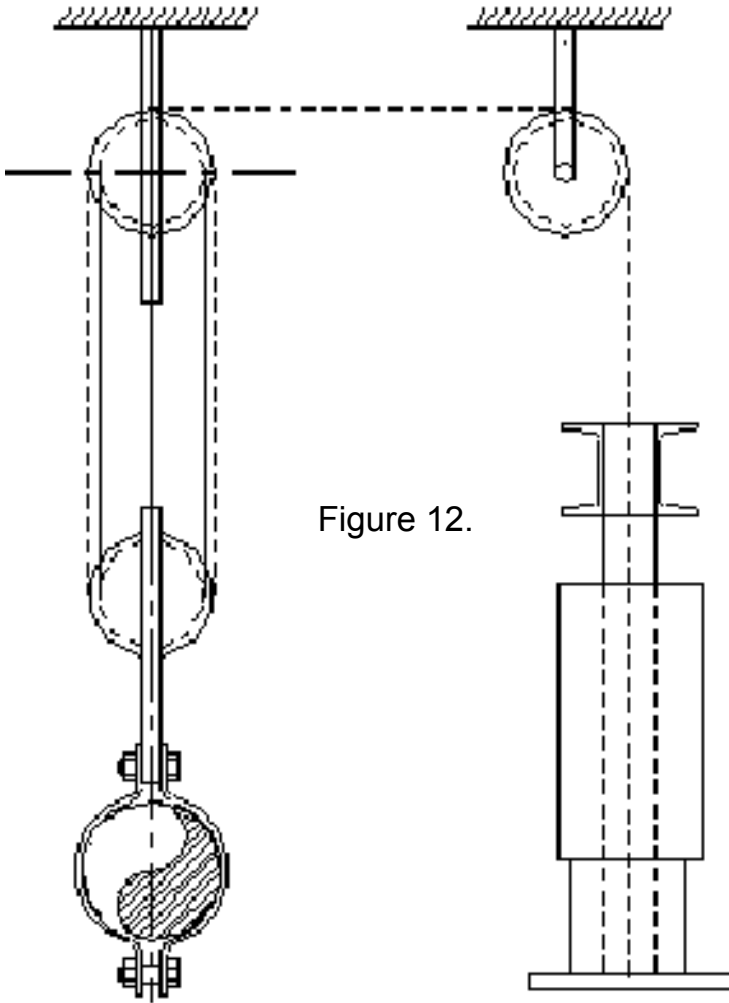

7.6 Spring Supports

7.6.4 Constant springs

In offshore contexts, a coil spring that works on the pipe through a mechanism is the most common temporary solution, where the geometry is selected so that the change of the spring force is compensated by the mechanism.

A constant spring is characterized by two parameters:

- Load
- Permitted movement

The desired load may be adjusted to some degree for a concrete spring.

7.6 Spring Supports

7.6.4 Constant springs

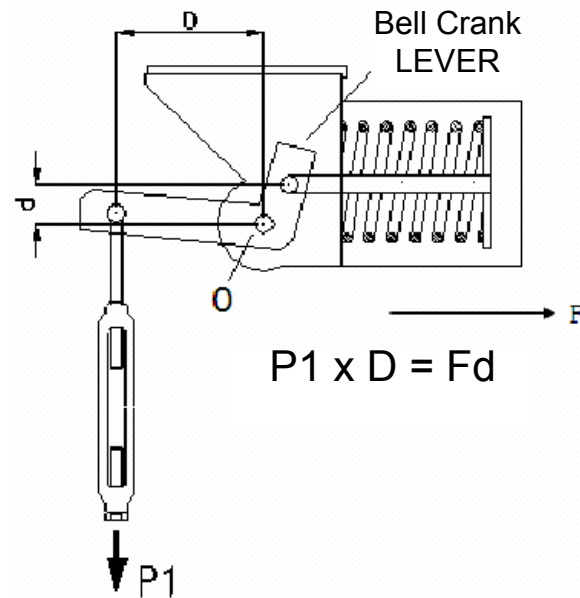

Figure 13.

7.6 Spring Supports

7.6.4 Constant springs

The constant spring is also equipped with a transport protection device. This normally consists of a bolt that locks the mechanism.

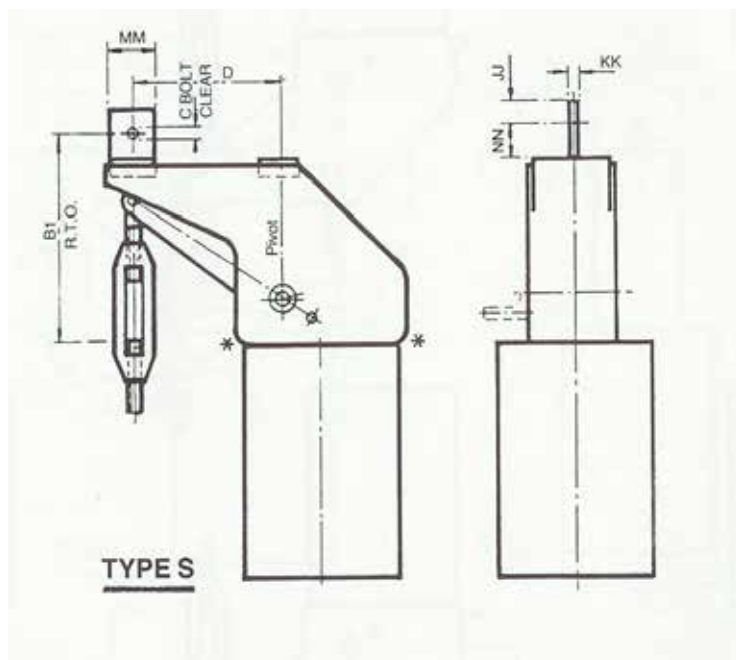

Figure 14.

There is a little guide that marks the spring's position in relation to the total movement the spring permits (see figure 15). On the scale, two positions are normally labeled. The one position corresponds to the installation position for the spring and the other corresponds to the position with the pipe in operation.

7.6 Spring Supports

7.6.4 Constant springs

The spring supplier sets these labels based on information given in the order. The stress analysis is a basis for this information, and the same spring forces that are marked on the spring should normally also be found on the “stress-iso”.



Figure 15.

7.6 Spring Supports

7.6.5 Installation in a cold system

The supplier normally has created an installation guideline that should be followed by the assigned personnel. If the installation guidelines are not attached to the work package, the assigned unit should ask to get them sent and should study them carefully before the work is done.

7.6 Spring Supports

7.6.5 Installation in a cold system

The spring is installed mechanically and the turnbuckle is adjusted until the transport protection device begins to loosen. Afterwards, the transport protection device should be taken out. (See figures 4 and 8.)

Some types of springs use nuts to lock and adjust movement. Check the installation guidelines. (See figures 10, 11 and 16.)

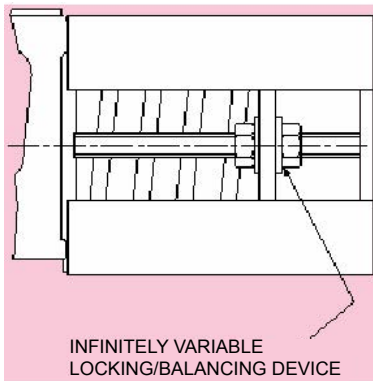

Figure 16.

This procedure also applies for use of a torque wrench.



7.6 Spring Supports

7.6.6 Installation in a hot system

When the spring comes from the supplier, it is adjusted for installation in a cold system. This means that if the spring is installed in the same way as described above, for an installation in a cold system, the spring's position will not be correct. The fact that the pipe will not be in the installation position needs to be compensated for.

To do this, those who are responsible for the installation need to find out at what height the pipe is. This should normally follow from a stress-iso. Here you should note that the values given on "stress-iso" normally refer to design temperatures, and it is not a given that the concrete pipe has exactly that temperature at the time of installation.

A typical example of this problem is springs on flow-lines. A flow-line connects the Christmas tree with production and test manifolds. Because of a combination of pressure, temperature and settings in the hill, the Christmas tree will move up and down. When the flow-line is in operation with maximum temperature and pressure, the spigot to the flow-line will be in its highest position, corresponding to the deformation that is used in the tension calculations. When a spring should be installed on a flow-line in operation, the flow-line will normally stay in a position somewhat under the maximum height dependent on how high the temperature and pressure of the media

7.6 Spring Supports

7.6.6 Installation in a hot system

is. In such a situation, you should evaluate in which position the spring should be adjusted. You cannot set it in an “installation-position” until later since this corresponds to the position for a cold well.

If the spring is installed as though the well were cold, the spring can exceed the allowed movement when the well comes down again. This will cause abnormally large forces on the supports and can cause damage.

The spring is installed mechanically and the turnbuckle is adjusted until the transport protection device begins to loosen. Thereafter, the transport protection device is taken out. When the transport protection is out, the turnbuckle can be adjusted further so that it compensates for the fact that the pipe is not in a cold position. This means that if the pipe is 10 mm higher than it would be in a cold position, the spring should be expanded 10 mm.

To install a spring in a system that is hot is a demanding job that requires technical knowledge and insight. Normally, the supervising “Pipe Stress Engineer” should be contacted and give advice and guidance to those who do the installation job.

7.6 Spring Supports

7.6.7 Inspection

In connection with inspecting the existing springs, the following points should be checked:

1. Locking bricks/nuts (variable springs) or locking pins (constant springs) should be removed.
2. The spring's position in relation to the system movement should be correct. Check this. If a scale is not visible, normally the spring should be replaced.

Different conditions over time can cause the situation to change so that the spring comes out of its original position. This can cause the spring to come outside of its work area, and this will then go to an end-position. If this occurs, the spring works as a fixed support and the face can be damaged.

7.6 Spring Supports

7.6.7 Inspection

3. General conditions: Over time, the spring may be damaged because of corrosion. Finally, the spring characteristics are changed because of reduced material, or that parts of the spring have broken off.
4. Check that “Spring Support” takes a load.
5. Condition of post and clamps around the pipe.
6. Check that movable parts are not corroded so much that they don’t function.
7. A “Spring Support” should not be replaced with a chain, post or other similar without this being approved in advance by a supervising “Pipe Stress Engineer”.

7.6 Spring Supports

7.6.7 Inspection

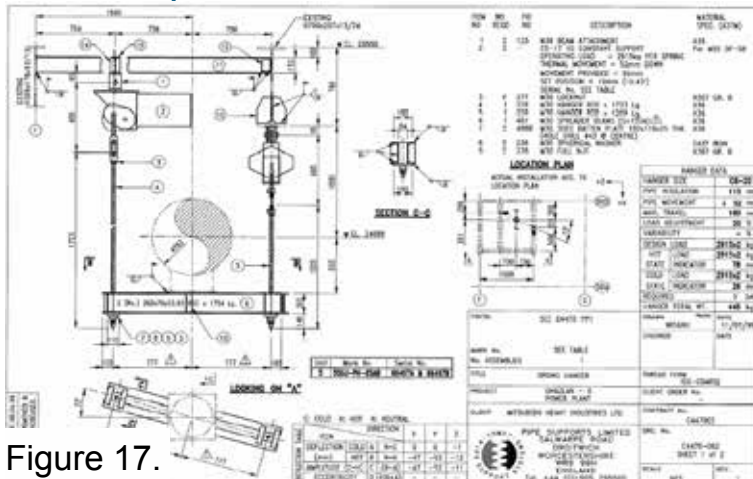

Figure 17.

Example-drawing of a hanging arrangement with springs.

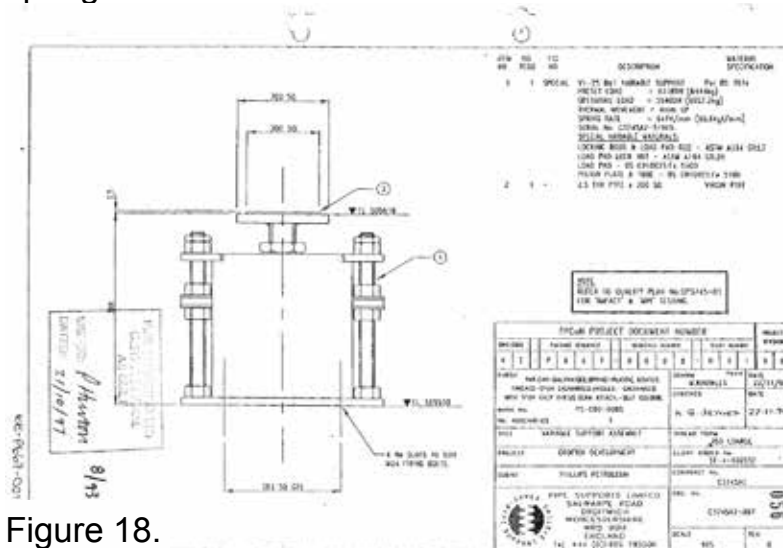

Figure 18.

Example of a detailed drawing of a spring. Note that the locking nuts are in a locked position and a spring is loaded.

7.7 Checklist for Leaking Flanges

(Installation) TAG NO.: _____

1: Flange size _____ Pressure rating _____ Spec.: _____

A: Flange material: Flange 1 _____ Flange 2 _____

B: Bolt size _____ Bolt quality _____

C: Distance flange flange at 12:00 pm _____ at 3:00 pm _____
at 6:00 pm _____ at 9:00 pm _____

D: Distance flange flange at the seal surface: at 12:00 pm _____ at 3:00 pm _____
at 6:00 pm _____ at 9:00 pm _____

E: Tool type used _____ Tool number _____ Pump pressure _____
Number of tools _____ Lubricant used _____

F: Gasket type used _____ Material _____ Size _____

G: Tension in the pipe system _____ Is the pipe ready for tightening? _____

H: Is the flange signed? _____ Is the right chart used? _____

I: Which pump pressure were the nuts loosened with? _____
PSI which tool no. _____
What does this correspond to in N·m? _____
How much should this be tightened according to the chart? _____

2: Is the ring in accordance with the pipe spec or the bolting chart? _____

A: Is the ring deformed? _____ Is it deformed evenly? _____
Is it deformed at points? _____

B: Is there movement in the ring when it is put into the track? _____

C: With use of a new ring is there movement in that? _____

D: Is the blind flange used? _____ Is this free of damage? _____

E: Have the rings been used several times? _____

F: Have the flanges been used several times? _____

G: Is the ring track within tolerances? _____

H: Are there foreign elements in the seal surface? _____ If so what? _____

Date: _____ Signature: _____

7.7 Checklist for Leaking Flanges



With leaking flanges: Lower pressure!

1. Check the parallelism of the flange, use feeler gate at 12:00, 3:00, 6:00 and 9:00 pm. See the tightening procedure.



2. Check that the bolting table that is used is in accordance with the actual line number.



3. Verify that all the bolts are tightened with the right moment. See the tightening procedure.

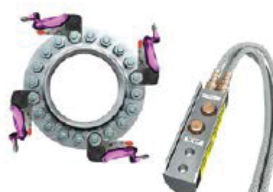

7.7 Checklist for Leaking Flanges

4. If the flange has any leaks, disassemble and check:

Gasket type, material quality, gasket size and pressure rating.

Deformations and damage to flange/contact surfaces.

Report to a qualified personnel for further evaluation.



5. Check that the contact surfaces and the bolt's threads are properly lubricated. Lubricate all the bolts.



6. Insert a new gasket and start the tightening procedure in accordance with the applicable bolting chart.

7.8 Example of Tightening Sheet



Tightening sheet with respect to OLF

ASSEMBLY

AO No.:

PIPE SPEC:

PIPE DIM:

	Type	Material
Gasket:	<input style="width: 95%;" type="text"/>	<input style="width: 95%;" type="text"/>

Date:

Done by:

TIGHTENING

Tool:

Pump pressure:

Moment:

Date:

Done by:

LEAK TEST			
<p>N₂ - TEST also includes N₂/Helium</p>	<p>TEST PRESSURE</p>	<p>WITH ERROR</p>	<p>DD.MM.YY</p>
<p>Gas test Process pressure</p>	<p>TEST PRESSURE</p>	<p>WITH ERROR</p>	<p>DD.MM.YY</p>
			<p>INITIALS</p>
			<p>INITIALS</p>
			<p>DATE</p>
			<p>SIGNATURE</p>
			<p>OK</p>
			<p>PRESSURE</p>

7.10 Revision changes

7.10.1 Revision 06, October 2019

1. Section 2 changes to torque setting for torque tool and pressure on wrench tool.
2. Lubrication of bolts on both sides on assembly
3. Additional examples of gasket types
4. Spring Support for information only
5. Inclusion of HX-ring for compact flanges



Norsk olje & gass

If you have any questions, feedback or comments on the contents of the handbook, contact Manager HSE and Standardization **Norwegian Oil and Gas Association** via the switchboard, telephone number +47 51 84 65 00.

www.norskoljeoggass.no